



**Request for Proposals**

**For**

**Shelby Building Project**

**Solicitation No. RFP-2021-10**

**Date of Release: September 3, 2021**

**Business**

**Office 2886 FM 1735**

**Mount Pleasant, Texas 75455**



## Request for Proposals

Northeast Texas Community College (NTCC) District invites all “qualified professional firm(s)” to submit request for Proposals (RFP) responses for NTCC’s **Shelby Building Project** for the following solicitation:

Request for Proposals (RFP) # RFP-2021-10

Submit response to:  
Northeast Texas Community College (NTCC)  
**Attention: Jeff Chambers**  
**# RFP-2021-10**  
2886 FM 1735  
Mount Pleasant, Texas 75455

By no later than: October 20, 2021 at 11:00 a.m., Central Standard Time (CST)

On the date and at the time for submission of proposals, responses will be opened and identified by proposer name. However, proposals will not be read aloud. Proposals that arrive after the date and time for submission of proposals will be considered late and will not be opened.

Proposals from respondents may not be withdrawn for a period of **one hundred twenty (120) days** subsequent to the date and time for submission without the consent of the Workforce Program Developer.

NTCC reserves the right to accept or reject any or all proposals in whole or in part, to waive informalities or technicalities, to clarify ambiguities, and to award items or groups of items as may be in the best interest of NTCC.



## TABLE OF CONTENTS

<b><u>1</u></b>	<b><u>ARTICLE 1 - GENERAL OVERVIEW AND EXECUTIVE SUMMARY .....</u></b>	<b><u>7</u></b>
<b><u>2</u></b>	<b><u>ARTICLE 2 – PROJECT OVERVIEW .....</u></b>	<b><u>12</u></b>
<b><u>3</u></b>	<b><u>ARTICLE 3 - AWARD OF CONTRACT.....</u></b>	<b><u>14</u></b>
<b><u>4</u></b>	<b><u>ARTICLE 4 - GENERAL INSTRUCTION .....</u></b>	<b><u>16</u></b>
<b><u>5</u></b>	<b><u>ARTICLE 5 - PROPOSAL SUBMISSION REQUIREMENTS .....</u></b>	<b><u>20</u></b>
<b><u>6</u></b>	<b><u>ARTICLE 6 – PROPOSAL EVALUATION .....</u></b>	<b><u>27</u></b>
<b><u>7</u></b>	<b><u>ARTICLE 7 - CONTRACT TERMS AND CONDITIONS .....</u></b>	<b><u>30</u></b>
<b><u>8</u></b>	<b><u>APPENDIX.....</u></b>	<b><u>37</u></b>
<b><u>9</u></b>	<b><u>CONSTRUCTION DOCUMENTS.....</u></b>	<b><u>50</u></b>



## DEFINITIONS

"Addendum" means a written clarification or revision to any solicitation issued by NTCC.

"Northeast Texas Community College" means NTCC, the College or District as established its procurement requirements under Texas Education Code, Chapter 44, NTCC Board of Trustees Policy CF (Local), Texas Government Code Procurement Laws, and the College's policies and procedures.

"NTCC Holidays" means when NTCC offices are officially closed. NTCC Holidays generally include Labor Day, Thanksgiving, Winter Break, MLK Day, Spring Break, and Memorial Day, in addition to other designated holidays identified as "College Closed" in the Academic Calendar published online at <https://www.ntcc.edu/academics/academic-calendars> for each academic year.

"Board of Trustees" means the governing body of NTCC.

"Centralized Master Bidders List (CMBL)" means the master database listing of active registered vendors and historically underutilized businesses (HUBs) mailing list for vendors to receive bid opportunities based on the products or services they can provide to the State of Texas.

"Contract" means the contract awarded as a result of this solicitation and all exhibits thereto.

"Contract Manager" means the College point of contact for all decisions or approvals, and shall include his or her designee(s) and such person or persons as may from time to time be authorized to represent NTCC with respect to any or all matters pertaining to food services.

"Contractor" means any vendor or supplier of commodities or services to a College under a purchase order contract or NTCC contract.

"Historically Underutilized Business (HUB)" means an entity as defined by Chapter 2161 of the Texas Government Code.

"Prime Contractor" means the lead contractor under an NTCC contract.

"Respondent" means the entity responding to this Solicitation or submitting a proposal response.

"Response" means a submission made in answer to an invitation for bid, request for proposal, request for qualifications, or other purchase solicitation document, which may take the form of a bid, proposal, offer, or other applicable expressions of interest.

"Solicitation" means any request for proposal, request for Proposals, or competitive sealed proposal, including any exhibits and addenda, if any.

"State" means the State of Texas and its instrumentalities, including NTCC, any other state agency or community college, its officers, employees, or authorized agents.

"Subcontractor" means a person who contracts with a prime contractor to work or contribute toward completing work for a governmental entity as defined by the Texas Government Code, Chapter 2251.



**ATTENTION INTERESTED RESPONDENTS**

NOTICE: This solicitation requires respondents to submit a number of signed documents with the proposal. Please use the included checklist in the Appendix Section to ensure that you are submitting all required signed documents with your proposal.

Failure to submit the required documents may result in automatic disqualification of your proposal response in accordance with NTCC's Rules and the advertised specifications.

NTCC may not accept exceptions to this solicitation. Responses may be rejected and not considered per ARTICLE 1, Exceptions section.

# 1 ARTICLE 1 - GENERAL OVERVIEW AND EXECUTIVE SUMMARY

NORTHEAST TEXAS COMMUNITY COLLEGE (NTCC) is soliciting proposals from **qualified service firms** for **Shelby Building Project**

NTCC Administration is responsible for the following responsibilities with respect to the selection of service providers for the proposed services.

- Serve as the primary/first contact with all external professionals who may be contracted for these projects;
- Develop and publicize scope of solicitation and evaluation criteria for selection of **Shelby Building Project**
- Submit rankings of Respondents to the solicitation evaluation committee for evaluation selection and approval; and
- Serve as contact and in oversight role throughout the procurement process.

Selection Process – The **Shelby Building Project RFP** is a **two (2) step process** for selecting a qualified firm, which includes the following:

- **Step 1:** Evaluation of Requests for Proposals responses from interested firms/Respondents to determine the competitive range among all Respondents for potential award of a contract; **and**
- **Step 2:** Review of the proposed rates (or fee schedules) that are published by the selected/qualified firm (see Section 6.2). Rates and fee schedules must be submitted in a sealed envelope marked “Rates and Fee Schedules”.

## 1.1 Authority

NTCC is soliciting the proposed services (or goods) listed herein under Texas Education Code, Chapter 44, Subchapter B, Section 44.031(f), Texas Government Code, Section 2254.003 and NTCC’s Board Policy CF (Local).

## 1.2 College Information

NTCC is a two-year community college providing university transfer, workforce training, continuing education, and adult basic education opportunities. In fall 2020, more than 2,800 credit and non- credit students took advantage of NTCC’s low tuition, small classes, convenient locations, and great instructors.

In the 1970’s & early 1980’s a group of citizens from Camp, Morris and Titus Counties decided that residents of this part of Northeast Texas deserved the opportunity for a better life through higher education. Northeast Texas Community College opened its doors just a few short years later in 1985. The NTCC District is composed of areas that support the college’s operations through an ad valorem tax. NTCC’s website is at <http://www.ntcc.edu>.

### 1.3 Point of Contact Information

All requests, questions or other communication about this solicitation shall be made in writing to the NTCC addressed to person listed below:

Name: **Jeff Chambers**  
Title: Vice President for Administrative Services  
Address: 2886 FM 1735, Mount Pleasant, TX 75455  
Phone: (903) 434-8106  
E-Mail: jchambers@ntcc.edu

### 1.4 Prohibited Communication

On issuance of this solicitation, except for the written questions and requests for clarification described in **Section 1.5 and 1.6 below**, NTCC, its representative(s), or partners will not answer any questions or otherwise discuss the contents of this solicitation with any potential Respondents or their representative(s).

Attempts to ask questions by phone or in person will not be allowed or recognized as valid. Respondents shall rely only on written statements issued by or through the College's designated staff as provided in this solicitation.

This restriction does not preclude discussions between affected parties to conduct business unrelated to this solicitation, including email.

Failure to comply with these requirements may result in disqualification of Respondent's proposal.

### 1.5 Clarifications

Respondents must notify the Point of Contact of any ambiguity, conflict, discrepancy, exclusionary specifications, omission or other error in the solicitation in the manner and by the deadline for submitting questions.

If a Respondent fails to timely and adequately notify the Point of Contact of such issues, the Respondent submits its proposals at its own risk, and if awarded a contract:

shall have waived any claim of error or ambiguity in the solicitation and any resulting contract, shall not contest the interpretation by the College of such provision(s), and

shall not be entitled to additional compensation, relief, or time by reason of ambiguity, error, or later correction.

### 1.6 Questions and Responses

Questions or comments concerning this solicitation must be submitted in writing to the NTCC's contact named in ARTICLE I, Point of Contact Information, by no later than the date and time indicated in Procurement Schedule of Events/Dates in this Section of the solicitation.



Responses to questions or other written requests for clarification may be posted on NTCC’s website. NTCC reserves the right to amend answers before the deadline of the solicitation’s responses. Amended answers may be posted on NTCC’s website. It is the Respondent’s responsibility to check the website or contact the Point of Contact for updated responses.

NTCC also reserves the right to determine or decline to answer any question or questions or to provide a single consolidated response of all matters they choose to respond in any manner at the sole discretion of the College.

If NTCC, in its sole discretion, determines that questions necessitate a change to this solicitation, the change will be reduced to writing in the form of an addendum and published on the NTCC’s website.

**1.7 Procurement Schedule of Events**

The following table documents identify the critical pre-award events for the solicitation.

Procurement Schedule	
Event	Dates
Solicitation Release Date	September 7, 2021
Pre-Bid Meeting 2:00 P.M.	September 28, 2021
Deadline for Questions	October 14, 2021
Issuance of Addendum, if required	October 15, 2021
Withdrawal of Solicitation (Same date as the due date/closing): 11:00 A.M.	October 20, 2021
Solicitation Response Due Date/Closing Date: 11:00 A.M.	October 20, 2021
Board of Trustees (BOT) Approval, as applicable	October 26, 2021
Contract Award	October 27, 2021
Anticipated Contract Start Date	November 1, 2021

**Note:** The dates identified are a tentative schedule of events. NTCC reserves the right to modify these dates at any time upon notice and at the discretion of NTCC, which will be posted to its website, via addenda.

**1.8 Alterations, Modifications, and Withdrawal of Proposal Prior to Deadline for Submission of Proposals**

NTCC reserves the right to change, amend or modify any provision of this solicitation or to withdraw this solicitation, at any time prior to award if it is in the best interest of the College and will post such on NTCC’s website. It is the responsibility of Respondent to periodically check NTCC’s website to ensure full compliance with the requirements of this solicitation.

Prior to the solicitation submission deadline, a Respondent may:

- Withdraw its solicitation response by submitting a written request to the Point of Contact identified in **Section 1.3**; or
- Modify its solicitation response by submitting a written amendment to the Point of Contact identified in **Section 1.3**.

NTCC may request proposals response modifications at any time prior to the submission deadline or closing date of the solicitation.

No proposal may be withdrawn for a period of **one hundred twenty (120) days** subsequent to the closing without the prior written approval of the Vice President for Administrative Services.

## **1.9 Multiple Responses**

A respondent may only submit one (1) proposal as a prime contractor. If a respondent submits more than one (1) proposal, NTCC may reject one or more of the submissions. This requirement does not limit a subcontractor's ability to collaborate with one or more respondents submitting proposals.

## **1.10 No Joint Proposals**

NTCC will not consider joint or collaborative proposals that require it to contract with more than one respondent.

## **1.11 Irregularities**

NTCC reserves the right to waive minor irregularities or genuine mistakes in a proposal and award a contract that is in the best of the College in determining the best value. NTCC may waive a minor irregularity or permit Respondents to correct a minor irregularity in a response if the irregularity:

- Is purely a matter of form rather than substance; and
- Does not affect price, quality, or delivery of the desired goods or services.

Any irregularities or lack of clarity in this solicitation should be brought to the attention of the Point of Contact listed in Section 1.3 as soon as possible so corrective addenda may be furnished to prospective Respondents.

## **1.12 Informalities**

NTCC reserves the right to waive minor informalities in a proposals response if it is in the best interest of the College. A "minor informality" is an omission or error that, in NTCC's determination if waived or modified when evaluating proposals responses, would not give a Respondents an unfair advantage over other respondents or result in a material change in the proposals response or the solicitation requirements.

## **1.13 Discrepancies**

Discrepancies or disparities between the contents of original proposal responses and copies will be interpreted in favor of NTCC. If Respondents fails to designate an "ORIGINAL," NTCC may reject the solicitation response or select a copy to be used as the original.

## **1.14 Exceptions**

NTCC will more favorably evaluate responses that offer no exceptions, reservations, or limitations to the terms and conditions of the solicitation. Any response that takes exception to any mandatory item(s) in this solicitation process may be rejected and not considered. Any response to the solicitation that does not include a response to all the required information may be rejected and not considered by NTCC. A notation of "Not applicable" as appropriate will be considered a valid response.

No exception, nor any other term, condition, or provision in a proposal response that differs, varies from or contradicts this solicitation will be considered to be part of any contract resulting from this solicitation unless expressly made a part of the contract in writing by NTCC.

## **1.15 Assumptions**

No assumptions should be included in a proposal response. The inclusion of assumptions in a proposal

response may result in a respondent not being awarded a contract.

A proposal response should be responsive to the solicitation as advertised, not with an assumption that any or all terms, conditions, or provisions of the solicitation will be negotiated. Furthermore, all proposal responses constitute binding offers.

Any proposal response to this solicitation that includes disclaimer or other statement indicating that the response does not constitute a binding offer may be disqualified.

## 2 ARTICLE 2 – PROJECT OVERVIEW

### 2.1 Mission Statement and Objective

The primary mission for this solicitation is to acquire the highest quality of goods and services in a timely manner that provided the best value to NTCC, and to assure that the procurement function is conducted for effective college operations and in accordance with applicable Federal and State laws, and NTCC policies.

### 2.2 Mission Objectives

NTCC's objectives of this solicitation are to contract with a qualified Professional Services Firm for the purpose of providing professional **Shelby Building Project** to the College District.

### 2.3 Description of Services/Scope of Work (SOW)/Specifications

NTCC is requesting interested firms to submit a proposal to provide the District with Shelby Building Project. The contractor shall furnish all labor, equipment, material and insurance necessary to perform the work as described below. All work shall be done by competent workers, skilled in the trades required for the work being performed.

This scope write up is NOT intended to define each and every possible task presented in the project documents, since the Contractor has demonstrated construction knowledge through experience on projects of similar size, type, and complexity. Any work that is reasonably implied and is necessary for the satisfactory completion of the project shall be performed as through it was explicitly indicated in the project documents.

#### 1) Demolition

- a) Removal of asphalt paving as indicated in construction documents.
- b) Removal of all roof panels, wall panels and gutters from existing building.
- c) Trees and brush to be cleared and removed from site as indicated in construction documents.
- d) Concrete drainage curb to be widened as indicated in construction documents.
- e) All materials to be removed off site unless otherwise directed by owner.

#### 2) Civil Site Work

- a) After removal of all asphalt paving in indicated areas, contractor to pour back designated hatches areas with slopes according to C1.01 (GRADING & DRAINAGE PLAN)
- b) Asphalt paving to abide by section 01/C1.02
- c) Provide underground electrical service to the new subpanel from existing service. Provide additional 2" PVC conduit with pull string to be used for future needs.
- d) Patch asphalt after conduit installation.

#### 3) Architectural

- a) Provide all doors with specified hardware listed in DOOR SCHEDULE per A1.01

#### 4) Structural Concrete

- a) Contractor to install footings, grade beams, stem walls and paving according to S1.01.
- b) New foundation shall be drilled and epoxied into existing foundation.
- c) Contractor to investigate existing foundation width & depths and report findings to engineer.
- d) New anchor bolts to be set and cast in concrete.

#### 5) Structural Steel

- a) Erection of new W12x30 columns, W16X31 beams, 8" purlins and wall girts, and X-Bracing.
- b) Installation of new roof panels, wall panels, trim, gutters and down spouts on entire project.
- c) Contractor shall erect building according to details shown on S2.01

**6) Lighting**

- a) Installation of new LED lighting - provide min 20 foot-candles.
- b) Installation of new receptacles (20 amp), 220V, and switches as shown on drawings at minimum.
- c) Exterior lighting to be on photocell.
- d) All exterior man doors to have exit sign lighting.
- e) Power to be routed to the building underground from main distribution panel. Contractor to patch trench with asphalt paving.
- f) E1.01 is shown for schematic purposes only and a minimum basis for design. All electrical work to be designed and completed by licensed electrician.

**2.4 Staff Resources Provided by NTCC**

NTCC shall have available appropriate staff to assist the selected contractor by providing required information and explanation.

**2.5 Working Space**

No storage space or office space will be provided for the Shelby Building Project Contractor

### 3 ARTICLE 3 - AWARD OF CONTRACT

The award shall not be made upon the opening of proposals but at a time as soon thereafter as may be necessary to evaluate proposals and to obtain Board of Trustee authorization, if required.

The provisions, terms, and conditions of this solicitation shall become a part of any subsequent contractual documents. Failure of the successful respondents to accept this obligation may result in the cancellation of any recommendation to award.

It is the intent of NTCC to award the contract to the qualified firm whose proposal, conforming to the conditions and requirements of the solicitation, is determined to offer the best value to NTCC.

Notwithstanding the above, this solicitation does not commit NTCC to contract for any requirements detailed in this document.

#### 3.1 Contract Type and Term

NTCC intends to award **one contract** as a result of this solicitation. Any award is contingent upon approval of the NTCC Board of Trustees or their delegate.

If for any reason, a final contract cannot be executed with a respondent selected for an award within **120 days**, NTCC may when applicable, select or negotiate a contract with the next highest scoring respondents or withdraw the solicitation.

#### 3.2 Contract Elements

The term “**contract**” means the contract awarded as a result of this solicitation and all exhibits thereto. At a minimum, the following documents will be incorporated into the contract: this solicitation and all attachments and exhibits; any modifications, addendum or amendments issued in conjunction with this solicitation; NTCC’s Terms and Conditions, and the successful respondent’s proposal.

#### 3.3 Contract Term

NTCC anticipates that the initial duration of **any contract resulting from this solicitation shall be for a period specified in Article 7 of this solicitation.** Following the base term and any allowable renewals or extensions, NTCC may extend any resulting contract for the purpose of completing a new procurement, and/or to transition to a new vendor if necessary to avoid interruption in District services.

#### 3.4 Contract Amount

The selected Respondent will be required to enter into a contract with NTCC substantially in the form of NTCC’s standard contract for **Shelby Building Project** with associated general conditions and attachments, which may be obtained from the NTCC Business Office upon request, without lengthy negotiations or extensive modifications to the terms. The Contract documents set out the insurance, prevailing wage rate and minimum wage requirements, payment and performance bond, and other requirements for the project.

The initial total compensation under any contract awarded, as a result of this solicitation, may exceed the amount of \$50,000. When applicable, the resulting contract(s) will require the NTCC Board of Trustees’ approval.

#### 3.5 No Guarantee of Volume, Partial Award/Non-Award

NTCC makes no guarantee of volume, usage, or total compensation to be paid to any Respondents under

any awarded contract, if any, resulting from this solicitation; any awarded contract is subject to appropriations and the continuing availability of funds.

NTCC reserves the right to cancel, make a partial award, or decline to award a contract under this solicitation at any time at its sole discretion.

External factors may affect the project, including budgetary and resource constraints. Any contract resulting from this solicitation is subject to the availability of state or federal funds. As of the issuance of this solicitation, NTCC anticipates that budgeted funds will be available to reasonably fulfill the project requirements. If, however, funds are not available, NTCC reserves the right to reject any and all proposals, withdraw the solicitation or terminate the resulting contract without penalty.

### **3.6 Use of Subcontractors**

Subcontractors providing services under the contract shall adhere to the same contract requirements in the delivery of the goods or services, and level of experience and Proposals as required of the Respondent. No subcontract under the contract shall relieve the Respondents of the responsibility for ensuring the requested services are provided. Respondents planning to subcontract all or a portion of the work to be performed shall identify the proposed subcontractors.

### **3.7 Performance Measures and Associated Remedies**

NTCC will monitor the performance of the contract issued under this solicitation. All services and deliverables under the contract shall be provided at an acceptable quality level and in a manner consistent with acceptable industry standard, custom, and practice.

Prior to the start or implementation of the contract, the selected vendor(s) must attend a post-award meeting with the responsible division/department, and other NTCC staff included with the management, performance, and oversight of the contract. The post-award meeting will provide information to examine all aspects and deliverables that will be associated with the contract.

## 4 ARTICLE 4 - GENERAL INSTRUCTION

### 4.1 Anti-Lobby and Restrictions on Communications with College Staff

From the issue date of this solicitation until contract award is made, respondents are not allowed to communicate about the subject of this solicitation with any NTCC's Faculty, Staff, or Members of the Board of Trustees except.

The NTCC contact named in ARTICLE I;

- NTCC representatives during a pre-proposal conference, if any;
- NTCC representatives during presentations, if any.

If a violation of this provision occurs, NTCC reserves the right to reject the proposal submitted by the offending Respondent.

### 4.2 Receipt of Proposals/Late Proposals

It is the sole responsibility of the Respondents to ensure timely delivery of its proposal to the NTCC. NTCC will not be responsible for the failure of service on the part of the U.S. Postal Service, courier companies, or any other mode of delivery chosen by respondent. Proposals received after the date and time specified for submission of proposals shall be considered late and shall not be considered for an award, unless it is determined by NTCC that late receipt was due solely to mishandling by NTCC after receipt of the proposal by NTCC. It is the responsibility of the respondents to ensure that their proposal arrives at the proper location by the date and time indicated in the solicitation.

### 4.3 Disclosure

Respondents shall note any and all relationships that might be a conflict of interest and include such information with the proposal. **(See Article 7, Contract Terms and Conditions).**

### 4.4 Costs for Responding

Respondents understand that issuance of solicitation in no way constitutes a commitment by NTCC to award a contract or to pay any costs incurred by respondents in the preparation of a response to this solicitation. NTCC is not liable for any costs incurred by a solicitation prior to issuance of or entering into a formal agreement, contract, or purchase order.

All cost(s) directly or indirectly, related to developing or preparing proposals, preparing for or participating in oral presentations, interviews and site visits, or any other similar expenses incurred by a respondent are entirely the responsibility of the Respondents and will not be reimbursed in any manner by NTCC.

### 4.5 Proposer Response, Texas Public Information Act and Proprietary Information

This solicitation specifies the format, required information, and general content of proposals submitted in response to this solicitation. NTCC's Business Office will not disclose any portions of the proposal prior to contract award to anyone outside the Business Office, NTCC's administrative staff, and the members of the evaluating committee; provided however, that if the NTCC Board of Trustees authorization is required, the departments' recommendation for award will be published as an agenda item.

NTCC is a public institution and subject to the Texas Public Information Act (Texas Government Code Chapter 552). Any information submitted to NTCC is presumed to be public information and available to the public. Any information or materials submitted to NTCC that is considered by the proposer to be confidential must be marked "CONFIDENTIAL," "TRADE SECRET," or "PROPRIETARY." If an outside



individual or entity requests review or copies of the information so marked, NTCC will advise the proposer of the request. If requested by the Respondents, NTCC will request an Open Records Decision from the Attorney General's Office of the State of Texas.

The Respondents shall be responsible for substantiating the confidentiality of the information or materials requested, **including all electronic submissions.**

#### **4.6 Disposition of Proposals**

All proposals become the property of the NTCC and will not be returned to the Respondent. The successful proposals may be incorporated into the resulting contract by reference. Disposition of unsuccessful proposals will be processed in accordance with NTCC open records policy.

#### **4.7 Rejection of Proposals**

In addition to those stated elsewhere in this solicitation, grounds for the rejection of proposals include, but shall not be limited to:

- Failure of a proposal to conform to the essential requirements of the solicitation.
- An offer imposing conditions that would significantly modify the terms and conditions of the solicitation or limit the proposer's liability to NTCC in any contract awarded based on such solicitation.
- Failure of the Respondents to certify the solicitation.

#### **4.8 Section Titles in the Solicitation**

The titles of paragraphs used herein are for the purpose of facilitating ease of reference only and shall not be construed to infer a contractual construction of language.

#### **4.9 No Contingent Fees**

No person or selling agency shall be employed or retained or given anything of monetary value to solicit or secure this contract, except bona fide employees of the Respondents or bona fide established commercial or selling agencies maintained by the Respondents for the purpose of securing business.

For breach or violation of this provision, NTCC shall have the right to reject the proposals, annul the contract without liability, or, at its discretion, deduct from the contract price or otherwise recover the full amount of such commission, percentage, brokerage or contingent fees or other benefit.

#### **4.10 Publicity Releases**

The firm shall not refer to award of the contract in commercial advertising in such a manner as to state or imply that the products or services provided are endorsed or preferred by NTCC.

#### **4.11 Conflicts of Interest**

A conflict of interest is a set of facts or circumstances in which either a Respondents or anyone acting on its behalf in connection with this procurement has past, present or currently planned personal, professional or financial interests or obligations that, in NTCC's determination, would actually or apparently conflict or interfere with the Respondent's contractual obligations to NTCC.

A conflict of interest would include circumstances in which a party's personal, professional or financial interests or obligations may directly or indirectly:

- make it difficult or impossible to fulfill its contractual obligations to NTCC in a manner that is consistent with the best interests of the College;
- impair, diminish or interfere with that party's ability to render impartial or objective assistance or advice to NTCC; or
- provide the party with an unfair competitive advantage in future NTCC procurements/solicitations.

Neither the respondents nor any other person or entity acting on its behalf, including but not limited to subcontractors, employees, agents, and representatives, may have a conflict of interest with respect to this procurement. Before submitting a proposal, respondents should carefully review NTCC's Terms and Conditions for additional information concerning conflicts of interests.

Respondents must certify that it does not have personal or business interests that present a conflict of interest with respect to the solicitation and resulting contract. Additionally, if applicable, the Respondents must disclose all potential conflicts of interest. The Respondent must describe the measures it will take to ensure that there will be no actual conflict of interest and that its fairness, independence, and objectivity will be maintained.

NTCC will determine to what extent, if any, a potential conflict of interest can be mitigated and managed during the term of the contract. Failure to identify potential conflicts of interest may result in NTCC's disqualifying of a proposal or termination of the contract.

#### **4.12 Appeal**

##### **4.12.1 Rights**

A Respondent who is aggrieved in connection with this procurement may appeal to the NTCC Vice President for Administrative Services.

#### **4.12.2 Notification**

The appeal shall be submitted in writing to the NTCC Vice President for Administrative Services and received in the NTCC within ten (10) business days after award of any contracts, which the aggrieved knows or should have known the facts giving rise thereto.

#### **4.12.3 Resolution**

NTCC's Vice President for Administrative Services shall review and determine the validity of the appeal. If a mutual resolution is not made, then the appeal shall be submitted to the President or his designee. Respondents must maintain compliance with Sections 1.4 and 5.12 of this solicitation during any appeal process. Any Respondent not maintaining compliance with the solicitation requirements may be rejected and may not be considered for award.

#### **4.12.4 Authority**

The Vice President for Administrative Services or his designee shall have the final authority for determination and take any action to resolve the appeal.

#### **4.12.5 Interpretive Conventions**

Whenever the terms "shall," "must," or "is required" are used in this solicitation in conjunction with a specification or performance requirement, the specification or requirement is mandatory. A respondent's failure to address or meet any mandatory requirement in proposals may be cause for NTCC's rejection of the proposal. Whenever the terms "can," "may," or "should" are used in this solicitation in conjunction with a specification or performance requirement, the specification or performance requirement is a desirable, but not mandatory, requirement. accordingly, a respondent's failure to address or provide any items so referred to will not be the cause for rejection of the proposal but will likely result in a less favorable evaluation.

## 5 ARTICLE 5 - PROPOSAL SUBMISSION REQUIREMENTS

### 5.1 Required Format

Proposals should be prepared economically and with an emphasis on completeness and clarity of the content.

The proposal must be:

- Formatted in US Letter size, 8 ½" x 11."
- Formatted in Arial or Times New Roman font, size 12 for standard text, and no less than size 10 font for tables, graphs, and appendices.
- Include a cover page with solicitation number and submittal deadline
- Organized in sequence as outlined in Article 5 of the solicitation
- Include respondent's name on the cover page
- Labeled with proposal name on each page
- Sequentially page-numbered
- Tabbed
- Bound in a single volume

To be considered for an award, respondents must respond to all sections of the solicitation, adhere to all requirements of the solicitation and provide all other required information and documentation as set forth in this solicitation.

### 5.2 Page Limit and Supporting Documentation

In general, proposals should not exceed fifty (50) pages in length, not including appendices or attachments.

### 5.3 Supporting Documentation

If complete responses cannot be provided without supporting documentation, the proposal must reference the specific tab, page, section, and/or paragraph where the supporting information can be found.

### 5.4 Number of Copies

Respondents must submit:

- **One (1) hard copy of the original Business proposal (Part I)**, and an authorized representative must sign the cover letter and all forms in original proposal in ink,
- **One (1) individual electronic copy of the Business proposal (Part I) on a USB flash drive** and saved in a Portable Document Format (PDF),
- **One (1) hard copy of the Respondent's Cost Proposal (Part II)**, and,
- **One (1) individual electronic copy of the Cost Proposal (Part II) on a USB flash drive** and saved in a Portable Document Format (PDF).

## 5.5 Labeling

Solicitation Responses shall be placed in a sealed envelope and clearly labeled as follows:

SOLICITATION NO:	RFP-2021-10
SOLICITATION NAME:	RFP for Shelby Building Project
SOLICITATION RESPONSE DEADLINE:	October 20, 2021
VENDOR NAME:	Respondent Name

NTCC will not be held responsible for any proposal response that is mishandled prior to its receipt. It is Respondent's responsibility to mark appropriately and deliver the proposal response to NTCC by the specified date and time.

## 5.6 Delivery

The only accepted methods of delivery are U.S. Postal Service, Overnight/Express Mail, or Hand Delivery. Proposals submitted by any other method will not be considered.

Delivery Address:

NTCC Business Office  
ATTN: Jeff Chambers  
2886 FM 1735  
Mount Pleasant, TX 75455

Once a proposal response has been submitted to NTCC, it becomes the property of NTCC and will not be returned to the respondent.

## 5.7 Submission

All submissions will be date and time stamped when received by NTCC. The clock in the NTCC's Business Office is the official timepiece for determining compliance with the deadlines in this procurement.

NTCC reserves the right to reject late submissions not received by the designated date and time specified in the solicitation. It is the respondent's responsibility to appropriately mark and deliver the proposal to NTCC by the specified date.

## 5.8 Required Content

All solicitation responses must be submitted in separate parts in accordance with Sections 5.1 and 5.3:

Part I, Business Proposal, and,

Part II, Cost Proposal.

Any proposal responses received without required documents may be deemed non-responsive in conjunction with the advertised specifications, and will not be considered for contract award.

## 5.9 PART I – Business Proposal

The business proposal must include the following information in tabbed sections, as follows:

- Tab 1: Transmittal Letter
- Tab 2: Required Documentation
- Tab 3: Respondent's Proposals (including engineering diagrams)
- Tab 4: Corporate Background and Experience
- Tab 5: Litigation
- Tab 6: Services Defined
- Tab 7: Value-Added Benefits
- Tab 8: Additional Information

### **5.9.1 Tab 1: Transmittal letter**

The transmittal letter shall be submitted on the respondent's letterhead and signed by an individual authorized to legally bind the proposer. It shall include:

A statement summarizing the Respondent's understanding of the work to be performed hereunder.

A statement acknowledging any addenda issued to this solicitation by NTCC.

A statement accepting financial responsibility for any expenses incurred in the preparation of the proposal, including travel expenses for oral presentations (if required), and candidate interviews.

A statement regarding any deviations from, or exceptions to this solicitation, including NTCC's Terms and Conditions and justification therefore. Any contract with conflicting terms and conditions must be placed in this tab along with a detailed description and justification.

Note: A proposal response that takes exception to any mandatory item in this solicitation may be rejected and may not be considered for award.

### **5.9.2 Tab 2: Required Documentation**

The following documents shall be submitted with the firm's (or Respondent's) solicitation response:

- Completed and signed Certification Form (Exhibit A);
- Vendor Application Form (Exhibit B);
- Respondent's Affidavit of Non-Collusion (Exhibit C-1);
- Conflict of Interest Questionnaire (Exhibit C-2);
- Proof of Insurability in accordance with NTCC's Terms and Conditions set forth in Article 7, Section 7.4 and as follows:
- Respondent must demonstrate they have the appropriate general liability insurance as set forth in NTCC's Terms and Conditions found in Article 7, Section 7.4.4
- Specify the bond, professional liability, or comparable insurance coverage maintained by the company. Certification of bond, when the application must be presented within ten (10) calendar days of notification.
- Respondent must show evidence of possessing Workers' Compensation Insurance as required by law.
- IRS W-9, Request for Taxpayer Identification Number and Certification (see [www.irs.gov](http://www.irs.gov)).

### 5.9.3 *Tab 3: Respondent Proposals for Project*

The purpose of the Proposals section is to determine whether the Respondent's response meets the minimum requirements necessary to provide the services, which are the subject of this solicitation.

When requested, the Respondent must furnish certification of authority to conduct business in the State of Texas. Registration is obtained from the Texas Secretary of State or specified county office, which will also provide certification thereof.

Respondent must not have had a contract terminated for cause with any customers within the last **twenty-four (24) months**.

Respondent must not have filed bankruptcy within the past **ten (10) years**.

### 5.9.4 *Tab 4: Corporate Background and Experience*

The following information shall be submitted with the firm's (or Respondent's) solicitation response:

**Business Organization:** State the firm's legal name. Give the firm's principal address and the satellite office(s) from which services under this contract will be conducted (if any). Provide company background and information. Identify parent company if you are a subsidiary. Provide a brief background description of your company, including the name(s) of its owner(s) and/or its principal officer(s), the date of origin and/or incorporation. Provide the number of years the firm has been in business, and the number of years the firm has been in business at its principal address.

**Record of Service:** Provide details of your firm's experience demonstrating your ability to successfully provide services (or goods) proposed, and the number of years the firm has actively provided the proposed services (or goods).

Provide specific projects and related responsibilities; describe those provided to higher education institutions, if applicable. Give details on other prior projects providing services related to the solicitation for other public-sector clients. Indicate if licensed to provide services in the State of Texas and provide proof of licensure.

Discuss what other relevant services your firm provides along with your proposed solution that may be beneficial to NTCC.

**Personnel and Résumés:** Identify and describe the respondent's and its subcontractor's proposed labor skill set and provide résumés of all proposed key personnel (as defined by the respondent). Résumés must demonstrate experience germane to the position proposed. Résumés should include work on projects cited under the respondent's corporate experience, and the specific functions performed on such projects. Each résumé should include at least three (3) references from recent projects. References may not be the Respondent's or subcontractor's employees.

**References:** Proposers must provide three (3) references for which the firm has provided the **proposed services (or goods)**. References must include the name of the company/institution, length of service, contact person, present address, phone number, and email. Experience providing similar services to higher education entities is preferred but not mandatory. References may be checked by NTCC prior to recommendation for award. The successful firm must satisfactorily demonstrate to NTCC experience in providing the **proposed services (or goods)**.

Financial Capacity to Perform:

Bidders are not required to submit evidence of financial capacity with their bids. NTCC

reserves the right to request such information at a later date.

**Conclusion and Proposal Summation:** Condense and highlight the contents of the proposals in such a way as to give the evaluation committee a complete understanding of the firm's proposal.

#### **5.9.5 Tab 5: Litigation**

Is your firm a party, in any capacity, to any current, actual or pending litigation? If yes, provide the details of the litigation and explain in detail.

Within the last **six (6) years of business**, has your firm, any predecessor of your firm, or any member of your firm been the subject of any stop order, consent decree, censure, reprimand, or any other disciplinary action? If yes, explain in detail.

Respondent shall disclose any lawsuits in which the firm is or was a party, for the **preceding five (5) years, and the resulting outcomes**. If the **Respondent becomes a party of any lawsuit within 60 days after proposal submission**, the Respondent's must notify NTCC immediately.

#### **5.9.6 Tab 6: Services Defined**

Fully describe the services your firm will provide to NTCC (See **Article 2**, Scope of Work). Include detailed information regarding your firm's controls relevant to the confidentiality, sensitivity, privilege, and privacy of student information, and controls to protect the security and integrity of NTCC data.

#### **5.9.7 Tab 7: Value-Added Benefits**

Describe any services or deliverables that are not required by the proposal that the Respondent proposes to provide at no additional cost to NTCC. Respondents are not required to propose value-added benefits, but the inclusion of such benefits may be considered more favorably.

#### **5.9.8 Tab 8: Additional Information.**

Include any additional relevant information not requested above for consideration.

### **5.10 PART II - Cost Proposal**

The cost proposal must include the following information in tabbed sections, as follows:

#### **5.10.1 TAB 1: Cost of Services and All Elements of Cost**

Respondents must base their cost proposals on the Scope of Work described in **Article**. This section should include any business, economic, legal, programmatic, or practical assumptions that underlie the proposed cost for the Services. NTCC reserves the right to accept or reject any assumptions.

Respondent must describe all costs or range of costs (one-time and ongoing) associated with the proposed solution, identifying separately by line item estimated product fees, relevant fee rates, implementation support fees, customer support fees, ad hoc consulting fee and any other potential industry costs associated with the purchase. In addition to possible license costs, what other costs are associated with successful implementation.



Related support costs the company provides to assist in the implementation process and throughout the life of contracts established (or product purchase) costs for all items proposed in the solution.

If applicable, the respondent must separately identify transition costs, value-added benefits, cost-savings, and cost-avoidance methods and measures, and the effect of such methods in accordance with the Scope of Work.

Note: Respondents must submit their cost for the proposed, clearly marked with the respondent's name, the solicitation number, and the solicitation submission date.

#### **5.11 Access to Financial Data**

The selected contractor will have limited access to the NTCC's financial data. The selected contractor must have an approach to ensure security and measures that will provide security and protection of NTCC systems. The selected contractor must also have an approach to providing NTCC with a disaster recovery plan. In addition, the selected contractor must, upon request, provide documentation on its proposed security and disaster recovery solutions.

#### **5.12 Bonding**

NTCC reserves the right to require the Respondents to procure one or more performance, fidelity, payment, or other bonds, if during the term of the contract. NTCC in its sole discretion determines that there is a business need for such a requirement.

#### **5.13 Certifications and Other Required Forms**

NTCC encourages respondents to carefully review all forms and submit questions regarding the proposal requirements prior to the proposal submission deadline identified in **Article 1**.

#### **5.14 News Releases**

Prior to the final award, Respondents may not issue a press release or provide any information for public consumption regarding its participation in the procurement.

Requests should be directed to the NTCC Point of Contact identified in **ARTICLE 1**.

#### **5.15 Incomplete Proposals**

NTCC may reject without further consideration a proposal that does not include a complete, comprehensive, or total solution as requested by the solicitation.

#### **5.16 Copyright Restriction**

NTCC will not consider any proposal that bears copyright.

#### **5.17 Additional Information**

By submitting a proposal, the Respondents grants NTCC the right to obtain information from any lawful source regarding the respondent's and its directors', officers', and employees':

- past business history, practices, and conduct;
- ability to supply the goods and services; and ability to comply with contract requirements.

By submitting a proposal, a Respondent generally releases from liability and waives all claims against any party providing NTCC information about the Respondent. NTCC may take such information into consideration in evaluating proposals.

## 6 ARTICLE 6 – PROPOSAL EVALUATION

Proposals will be evaluated in accordance with Texas Education Code, Chapter 44, Subchapter B, Section 44.031(f), Texas Government Code and Section 2254.003 associated with the proposed services, as follows:

An evaluation committee will conduct evaluations of the submitted proposals.

Any response that takes exception to any mandatory item(s) in this solicitations process may be rejected and not considered. Any response to the solicitation that does not include a response to all the required information may also be rejected and not considered.

A notation of “Not applicable” as appropriate will be considered a valid response.

### 6.1 Evaluation and Selection:

NTCC will review submissions of proposals and select finalists based upon the listed evaluation criteria. NTCC reserves the right, at its sole discretion, to accept the proposal, which it considers most favorable to the College's interest.

NTCC reserves the right to negotiate, when applicable, with any and all Respondents regarding their proposal, and to request oral presentations from any one or all respondents. NTCC reserves the right to accept or reject any qualified proposal, to reject any and all proposals, and to waive minor informalities.

NTCC will use a formal evaluation process to select the successful respondent. NTCC will consider capabilities or advantages that are clearly described in the proposal, which may be confirmed by oral presentations, site visits, demonstrations, and references contacted by NTCC. NTCC reserves the right to contact individuals, entities, or organizations that have had dealings with the respondent or proposed staff, whether or not identified in the proposal.

NTCC will more favorably evaluate proposals that offer no or few exceptions, reservations, or limitations to the terms and conditions of the solicitation, including the NTCC's Terms and Conditions.

### 6.2 Evaluation Criteria

The NTCC Board of Trustees has delegated the Vice President for Administrative Services to select the following criteria for evaluating firms to provide **Shelby Building Project** as part of the overall contracting process provided in the Texas Education Code Section 44.031 to contract from this solicitation. **NTCC will evaluate proposals based on demonstrated competence and Proposals and the fairness and reasonableness of the price.** To evaluate these criteria, NTCC will consider the following factors:

#### 6.2(A) Selection Process:

**Step 1:** Respondents who submit timely responses to this RFP will be evaluated and ranked in the competitive range of scores among all Respondents, which the Respondent receives according to the selection criteria in **Section 6.2(B)**.

**Step 2:** Qualified Respondent's rates (or fee schedules), which are submitted in response to the RFP will be reviewed, for reasonableness, by the selection committee to determine the overall best value to NTCC for this procurement and project.

The selection committee may also conduct interviews.

**6.2 (B) Selection Criteria:** Respondents to the RFP will be evaluated and ranked based on the competitive range of scores among all Respondent based on the criteria and weights listed below:

Overall Contract Cost **(20%)**

Quality, reliability and successful experience of the Respondent in the last five (5) years of past performance of Pre-Engineered Buildings to other community colleges, institutions of higher education and other governmental and public entities, etc., for similar projects **(25%)**.

Quality of the Respondent services defined and the extent to which services meets NTCC's needs **(25%)**.

Overall Qualifications of the Respondent's proposed staff **(20%)**.

Quality and responsiveness of the submittal **(10%)**.

Acceptance of Evaluation Methodology:

By submitting a proposal in response to **RFP** respondent accepts the evaluation process and acknowledges and accepts that determination of the "most qualified" firms/respondents will require subjective judgments by the Owner.

BY SUBMITTING A RESPONSE TO THIS RFP THE RESPONDENT AGREES THAT IT WAIVES ANY CLAIMS IT HAS OR MAY HAVE AGAINST NTCC, NTCC'S EMPLOYEES, OFFICERS, AGENTS, REPRESENTATIVES AND MEMBERS OF NTCC'S GOVERNING BODY, IN CONNECTION WITH OR ARISING OUT OF THIS RFP INCLUDING THE ADMINISTRATION OF THE RFP THE BASIS FOR SELECTION, THE EVALUATION OF THE RESPONSES, THE METHOD USED FOR SELECTION, AND ANY DISCLOSURE OF INFORMATION REGARDING THE RESPONSES OR EVALUATIONS. THE SUBMISSION OF PROPOSALSS CONSTITUTES THE ACCEPTANCE BY THE RESPONDENT OF THE EVALUATION TECHNIQUE DESCRIBED IN THIS RFP.

### **6.3 Initial Compliance Screening**

NTCC will perform an initial screening of all proposals received. Unsigned proposals are subject to rejection without further evaluation. Proposals that do not include all required forms will result in automatic disqualification.

### **6.4 Competitive Range Determinations**

NTCC may determine that certain proposals are within the competitive range for consideration for negotiation and possible contract award, for proposals that receive the highest or most satisfactory evaluation. NTCC may, in the interest of administrative efficiency, place reasonable limits on the number of proposals that will be included in the competitive range.

### **6.5 Pre-Bid Meetings**

NTCC will hold **1** pre-bid on-site meetings. During these meetings, NTCC will provide a **walkthrough** of the **site**, discuss expectations and answer any questions. Attendance at the meeting **is optional, but strongly recommended**. The meeting is scheduled for **September 28, 2021**. The meeting will

begin promptly at 2:00 PM in the Biggers Room located in the Learning Commons Building on the NTCC campus.

#### **6.6 Oral Presentations and/or Site Visits for the Purpose of Demonstrations**

NTCC may, at its sole discretion, request oral presentations, site visits, and/or demonstrations from one or more respondents included in the competitive range. NTCC will notify selected respondents of the time and location for these activities and may supply agendas or topics for discussion. NTCC reserves the right to ask additional questions during oral presentations, site visits, and or demonstrations to clarify the scope and content of the written proposal.

The respondent's oral presentation, site visit, and/or demonstration must substantially represent material included in the written proposal, and should not introduce new concepts or offers unless specifically requested by NTCC.

#### **6.7 Best and Final Offers**

NTCC may, but is not required to, permit proposals to prepare one or more revised offers. For this reason, respondents are encouraged to treat their original proposal, and any revised offers requested by NTCC, as best and final offers.

#### **6.8 Clarifications with Respondents**

NTCC may, but is not required to, conduct clarifications with all, some, or none of the respondents included in the competitive range for the purpose of obtaining the best value for NTCC. NTCC may conduct clarification for the purpose of:

- clarifying proposal's ambiguities;
- requesting modifications to a proposal; and/or
- obtaining a best and final offer.

NTCC may make an award that represents the best value to the College.

## 7 ARTICLE 7 - CONTRACT TERMS AND CONDITIONS

### 7.1 Scope of Work

Respondent shall provide NTCC **Shelby Building Project** Such goods and services are to be provided in accordance with the provisions, terms and conditions of the resulting contract and consistent with Respondent's proposal response to NTCC's **RFP # RFP-2021-10 (the "RFP")**. The **RFP** and Respondent's proposal response ("Response") are both incorporated to the resulting contract for all purposes and will be attached hereto the resulting as Exhibits "A" and "B" respectively.

### 7.2 Term of Contract and Renewal

Assuming continued availability of funding, the term of this Contract shall commence on "Effective Date" and shall terminate at completion of the project.

### 7.3 Compensation

Vendor shall be compensated for satisfactory goods received and services performed pursuant to this Contract, which pricing shall be based upon the price and fee schedule established in Vendor's Response in Step 2.

The compensation payable under this Contract must be approved by the NTCC Board of Trustees because the resulting contracts may exceed Fifty Thousand Dollars (\$50,000.00) per fiscal year, unless otherwise provided by written amendment hereto.

### 7.4 NTCC's TERMS AND CONDITIONS

#### 7.4.1 *Contract Not a Guarantee of Purchase*

This Contract is not a guarantee of purchase. Purchases shall be made subject to fund availability, budgetary concerns, and other matters affecting, or which may affect, the services to be performed.

#### 7.4.2 *Warranty*

As applicable, unless otherwise agreed in writing prior to award, the warranty for all goods or services purchased under this Contract shall be from the date of installation. Vendor must be an authorized dealer, distributor or manufacturer of the product(s) offered.

#### 7.4.3 *Indemnification*

TO THE MAXIMUM EXTENT PERMITTED BY LAW, VENDOR SHALL SAVE AND HOLD HARMLESS AND INDEMNIFY NTCC AGAINST ANY AND ALL LIABILITY,

CLAIMS AND COSTS OF WHATSOEVER KIND AND NATURE OCCURRING IN CONNECTION WITH OR IN ANY INCIDENT TO OR ARISING OUT OF THE PERFORMANCE OF WORK IN CONNECTION WITH THIS CONTRACT, INCLUDING ANY CLAIMS ARISING IN WHOLE OR IN PART OUT OF THE NEGLIGENT ACTS OR OMISSIONS OF VENDOR.

This clause shall survive the termination of this contract, until the period for which the Contractor is determined to be liable in accordance with local, state, or federal statutes or regulations.

#### **7.4.4 Insurance Requirements**

Successful contractor shall procure and maintain at its own expense the following minimum insurance coverages insuring all services, work activities, and contractual obligations undertaken in this contract. These insurance policies must be written by insurers acceptable to NTCC.

#### **7.4.5 Insurance limits for contracts over \$50,000 includes:**

Commercial General Liability Insurance

Covering all duties, services or work to be performed (under the contract); insurance will provide limits of:

Policy aggregate	\$2,000,000
Each occurrence	\$1,000,000
Products/completed operations aggregate	\$1,000,000

Professional Liability Insurance Limits

Aggregate	\$2,000,000
Each wrongful act	\$1,000,000

Automobile Liability Insurance

Aggregate	\$500,000
Per occurrence	\$500,000

Workers' Compensation Insurance

Providing the statutory benefits for the State of Texas and Employer's Liability Insurance for all contracts in the amount of:

Bodily Injury by accident:	\$1,000,000
Bodily Injury by person:	\$1,000,000

An Original Certificate of Insurance

**Must be submitted from the insurer/agent prior to the issuance of the Notice to Proceed.**

The insurance carriers must be acceptable to NTCC, generally an AM Best A- IX or better rating. The General Liability and Automobile Liability Certificate of Insurance must name Northeast Texas Community College District as an additional insured.

All certificates except Professional Liability shall include a Waiver of Subrogation for coverages. Vendors must maintain the required limits of insurance as specified in the contract. They must also inform the College of any changes in insurance carriers, policy effective dates, or agents at least 30 days prior to such change, except if the policy is canceled for non-payment of premium, in which case the notice shall be 10 days.

NTCC shall bear no financial responsibility for Contractor's insurance coverage

#### **7.4.6 PRICES AND INVOICING**

Prices shall be provided based on the prices and fee schedule provided in Vendor's Response. Pricing for any goods shipped to NTCC shall be FOB DESTINATION, Prepaid and Allowed to NTCC locations – NORTHEAST TEXAS COMMUNITY COLLEGE and shall include all charges associated with the cost of the completion of the contract.

Vendor shall submit an invoice with NET 30 day payment terms for services performed for NTCC under the terms of this Contract. The invoice shall be directed to Accounts Payable, Northeast Texas Community College at 2886 FM 1735, Mount Pleasant, Texas 75455 or [ap@ntcc.edu](mailto:ap@ntcc.edu). The invoice shall contain a complete itemization of delivered goods and/or services, the total amount due, invoice number, invoice date, the designated project number, if applicable, and NTCC's purchase order number. All payments for goods or services under this Contract shall be made in compliance with Texas Government Code Chapter 2551.

The invoice shall be directed to Accounts Payable, Northeast Texas Community College at 2886 FM 1735, Mount Pleasant, Texas 75455 or [ap@ntcc.edu](mailto:ap@ntcc.edu). The invoice shall contain a complete itemization of delivered goods and/or services, the total amount due, invoice number, invoice date, the designated project number, if applicable, and NTCC's purchase order number.

Prices shall remain firm during the initial term of the contract and for any extension thereof; provided, however, if contract costs have substantially and materially increased, Contractor may request a price increase. The request for price increases shall be submitted in writing at least sixty (60) days prior to the proposed effective date of the increase and shall be fully documented as to the reason(s) therefore. NTCC shall determine whether the request is reasonable and either grant the request, purchase services from another source, or re-bid the contract. The price increase cannot exceed 5% of the original contract price.

#### **7.4.7 Contracts Subject to Texas Business and Commerce Code**

Where applicable, this Contract is governed by, among other legal standards, Chapters 1-9 of the Texas Business and Commerce Code.

#### **7.4.8 Taxes**

NTCC is exempt from federal excise, state and local taxes unless otherwise stated in this document. NTCC claims exemption from all sales and/or use taxes under Texas Tax Code Section 151.309, as amended. To claim the benefit of this exemption for performance of work hereunder, Vendor must comply with such procedures as may be prescribed by the State Comptroller of Public accounts. Upon request, Texas Limited Sales Tax Exemption Certificates will be furnished to Vendor.

#### **7.4.9 Compliance with Laws**

Vendor shall comply with all federal, state, and local privacy laws or regulations applicable to the covered data and information provided by NTCC, including but not limited to: the Family Educational Rights and Privacy Pre-Engineered Building FIRM of 1974 (FERPA); the Health Insurance Portability and Accountability Pre-Engineered Building FIRM of 1996 (HIPAA); Standards for Privacy of Individually Identifiable Health Information. In the event of a security breach within the Vendor's control and covered under the Texas Breach Notification Law (Texas Business and Commerce Code, Chapter §521), Vendor shall bear all responsibility and expense for complying with the disclosure and notification requirements under that statute.



#### **7.4.10 Severability**

If any section, subsection, paragraph, sentence, clause, phrase or word of these requirements or the specifications shall be held invalid, such holding shall not affect the remaining portions of these requirements and the specifications and it is hereby declared that such remaining portions would have been included in these requirements and specifications as though the invalid portion had been omitted.

#### **7.4.11 Assignment**

Neither this contract nor any portion of it may be assigned without the written approval of NTCC's Vice President for Administrative Services.

#### **7.4.12 Conflict of Interest**

No contract for the purchase of personal property or service shall be awarded to any vendor where the contract would violate the applicable state laws and NTCC's policies and regulations regarding conflicts of interest. NTCC trustees, employees, and their spouses, are prohibited from accepting gifts or entertainment from vendors of NTCC. Additionally, NTCC is prohibited from entering into any contract and shall not do business with any of its trustees, its employees, or their spouses.

In accordance with Chapter 176, Local Government Code, any individual or business entity that contracts for the sale or purchase of property, goods, or services with NTCC must file a Vendor Conflict of Interest Questionnaire with the Business Office of NTCC, whether or not a conflict exists, and in the event that a conflict arises, no later than the 7th business day after Vendor becomes aware of facts that require filing.

Form CIQ, Conflict of Interest Questionnaire for Vendor or Other Person Doing Business with Local Government Entity can be found at: [www.ethics.state.tx.us/filinginfo/conflict\\_forms.htm](http://www.ethics.state.tx.us/filinginfo/conflict_forms.htm).  
**(Exhibit C-2)**

#### **7.4.13 Termination for Convenience**

The performance of work, services, or provision of goods under this contract may be terminated by either party in accordance with this clause in whole or, from time-to-time, in part, whenever it is determined that such termination is in the best interest of NTCC or Vendor. Any such termination shall be effected by delivery of a "Notice of Termination" to the other party, specifying the extent to which performance of work under this Contract is terminated and the date upon which the termination becomes effective. In the event such termination is exercised by NTCC, NTCC shall be liable for the payment of all approved work performed prior to the Notice of Termination. In the event such termination is by Contractor, Contractor shall either perform all approved work or shall reimburse NTCC for payments already made to Vendor by NTCC; such reimbursement shall be acceptable to NTCC and shall be made within thirty (30) days of Contractor's Notice of Termination.

#### **7.4.14 Termination for Default**

By written notice, NTCC may terminate this Contract, in whole or in part, for failure of Vendor to perform any of the provisions of this Contract.

#### **7.4.15 Force Majeure**

Neither Party shall be responsible for delays or failures in performance resulting from acts of God,

strikes, lockouts, riots, acts of war, epidemics, fire, tornadoes, earthquakes or other natural disasters.

#### **7.4.16 Bankruptcy**

NTCC may terminate this Contract without prejudice to any rights hereunder for non-performance, as determined by NTCC, if Vendor files for voluntary bankruptcy; is determined to have made a transfer in fraud of its creditors; files a legal proceeding under any similar law or statute of the United States or any state thereof; a permanent receiver or trustee in bankruptcy is appointed for Vendor; or if an order for relief shall be entered against the financial institution in any proceedings filed by or against the financial institution there under.

In the event that a proceeding for involuntary bankruptcy is instituted against Vendor, the act of such an involuntary petition has been filed shall not be considered an event of default until sixty (60) days after the filing of said petition for involuntary bankruptcy, in order that the financial institution might, during that sixty (60) days period, have the opportunity to seek dismissal of the involuntary petition or otherwise cure said potential default.

#### **7.4.17 Attorney's Fees**

If either party hereto should retain legal counsel for the purpose of enforcing any term or condition of this Contract in court, then the prevailing party shall be entitled to recover all damages, costs, and expenses, including but not limited to, reasonable and necessary attorney's fees thereby incurred.

#### **7.4.18 Dispute Resolution**

The Parties hereto shall attempt to resolve any controversy or claim arising from any contractual matter by non-binding mediation. When one Party to this Contract determines that a dispute exists and invokes this clause, the parties will have 30 days to agree on a mediator. If no mediator can be agreed upon within 30 days after this clause is invoked, either party may proceed to file an action in court to resolve the initially identified dispute. Both Parties shall share equally in the costs assigned thereto, and mediation shall take place within the Northeast Texas Community College taxing district.

#### **7.4.19 Governing Law and Venue**

This Contract shall be construed in and governed under and by the laws of the State of Texas, without giving effect to its Choice of Law provisions. Venue for any action or remedy pursued by either party shall be pursued in a court of competent jurisdiction in Titus County, Texas, only after the parties have jointly participated in a non-binding mediation session as required by 7.17.

#### **7.4.20 Successors**

This Contract shall be binding upon and inure to the benefit of the Parties hereto and their respective successors and assigns. Whenever a reference is made herein to either party, such reference shall include the party's successors and assigns.

#### **7.4.21 Extra Contractual Products and Services**

NTCC reserves the right to purchase products and services of a related or similar nature and kind from Vendor. Such services and products, if purchased, shall be on an as needed basis at Vendor's then prevailing prices; provided that such prices are deemed reasonable by NTCC.

**7.4.22 Texas Government Code Chapter 2270 Compliance**

In compliance with Texas Government Code § 2270.002, Vendor verifies by its authorized signature below that it does not boycott Israel and will not boycott Israel for the term of this Contract.

**7.4.23 Exhibits**

The following Exhibits are attached hereto the solicitation and incorporated herein by reference and the rights and obligations contained therein are hereby incorporated into and shall be a part of the resulting contract and contained in the main body of the resulting contract.

RFP (as published)  
VENDOR RESPONSE  
PRICE SCHEDULE (if not set out in the Response)  
LETTER OF CLARIFICATION (if needed and noted in scope paragraph)

**7.4.24 Entire Agreement**

The resulting Contract constitutes the entire agreement between the Parties as to the subject matter hereof. All prior negotiations or representations, whether written or verbal, that are not incorporated herein are superseded by this Contract. No changes in or additions to this Contract will be recognized unless made in writing and signed by all Parties.

## SUBMISSION CHECKLIST

This checklist is provided for Respondent's convenience only and identifies documents that **must be submitted** with this Solicitation in order to be considered responsive. **Any proposal responses received without these requisite documents will be deemed non-responsive in conjunction with the advertised specifications, and will not be considered for contract award.**

- 1) One (1) "original" signed (hard copy) **Business Proposal response (Part I)**
- 2) One (1) individual electronic copies of the **Business Proposal (Part I)** on a USB flash drive (PDF Format)
- 3) One (1) "original" (hard copy) **Cost Proposal response (Part II)**
- 4) One (1) individual electronic copies of the **Cost Proposal (Part II)** on a USB flash drive (PDF Format).
- 5) Signed Addenda issued for the Solicitation (if applicable)
- 6) Respondent Certification Form (Exhibit A)
- 7) Vendor Application Form (Exhibit B) and W9 (IRS.gov)
- 8) Respondent's Affidavit of Non-Collusion and Non-Conflict of Interest and Anti-Lobbying (C-1 of 2)
- 9) Conflict of Interest Questionnaire (C-2 of 2)
- 10) **Business Proposal (Part I):** Section 5.8 (Items/TABs 1-7) and the following documents: 
  - Proof of Insurability
  - Proof of online registration
  - Evidence of Licensure
  - Litigation Disclosure
- 11) **Cost Proposal (Part II):** Section 5.9 (Item/TAB 1)

8 APPENDIX

**EXHIBIT A**

**CERTIFICATION FORM**

I hereby certify that the company whose name appears on this Certification, to submit this response and to execute a contract on behalf of said company.

I certify that this response is submitted with all items required under Part I of the invitation for solicitation; and

I certify that this response meets all the requirements of the solicitation, that it shall remain firm for a period of one hundred and twenty (120) days, and that I have read the terms and conditions and acknowledge that they shall be the terms and conditions of the purchase order contract awarded pursuant hereto.

Authorized  
Signature: \_\_\_\_\_

Print Name: \_\_\_\_\_

Title: \_\_\_\_\_

Company Name: \_\_\_\_\_

Company  
Address: \_\_\_\_\_

Telephone: \_\_\_\_\_

E-mail: \_\_\_\_\_

Date: \_\_\_\_\_

Federal Tax  
ID Number: \_\_\_\_\_

DUNS Number: \_\_\_\_\_

# EXHIBIT B

## Vendor Application Form

### Vendor Information

Company Name:

Order Address:	Remittance Address: <input type="checkbox"/> Same as Order Address
City, State Zip:	City, State Zip:
Phone #:	Fax #
Contact Name:	Contact Title:
Contact Email:	Company Website:
Tax ID/EIN #:	

Please indicate below all purchasing vehicles that this company currently participates in (mark all that apply):

<input type="checkbox"/> BuyBoard	<input type="checkbox"/> DIR	<input type="checkbox"/> TBPC	<input type="checkbox"/> TCPN	<input type="checkbox"/> TIPS/TAPS	<input type="checkbox"/> TPASS/TXMAS
-----------------------------------	------------------------------	-------------------------------	-------------------------------	------------------------------------	--------------------------------------

Other:

Please List:

The company listed above is a Historically Underutilized Business (HUB). (Please see Note below)	<input type="checkbox"/> Yes	<input type="checkbox"/> No
--	------------------------------	-----------------------------

**Note:** A Historically Underutilized Business is defined as a business wherein at least 51% of the ownership and management is by minority/women group members, or in the case of a publicly-owned business, at least 51% of the stock is owned and managed by minority/women group members with their principal place of business in Texas. To learn more about HUB please visit the State of Texas program page at, <http://www.window.state.tx.us/procurement/prog/hub>.

Please check the appropriate boxes below to indicate all general products or services offered by this company. Utilize the lines below to specifically describe all equipment, supplies, materials, goods and/or services (include brands or manufacturers if applicable).

<input type="checkbox"/> Athletic supplies/equip.	<input type="checkbox"/> Awards/Trophies	<input type="checkbox"/> Audio Visual equipment	<input type="checkbox"/> Building Maint. supplies
<input type="checkbox"/> Business/office supplies	<input type="checkbox"/> Vocational supplies	<input type="checkbox"/> First Aid / Medical supplies	<input type="checkbox"/> Floor covering/surfaces
<input type="checkbox"/> Food Services / Supplies	<input type="checkbox"/> Furniture	<input type="checkbox"/> Grounds Maint. supplies	<input type="checkbox"/> Instructional materials
<input type="checkbox"/> Library books / supplies	<input type="checkbox"/> Music / Art	<input type="checkbox"/> Paper / printing supplies	<input type="checkbox"/> Security supplies/equip.
<input type="checkbox"/> Technology	<input type="checkbox"/> Transportation	<input type="checkbox"/> Uniforms / apparel	

Other:

Please Describe:

# **EXHIBIT C-1 of 2**

## **8.1 Affidavit Prohibited Activities**

## **8.2 Solicitation Requirements, Contract Forms and Conditions of the Contract NORTHEAST TEXAS COMMUNITY COLLEGE DISTRICT**

## **8.3 RESPONDENT'S AFFIDAVIT OF NON-COLLUSION**

### **8.4 NON- CONFLICT OF INTEREST, AND ANTI-LOBBYING FOR SOLICITATION RESPONSE NO. \_\_\_\_\_**

The undersigned "Affiant" is a duly authorized representative of the Respondent for the purpose of making this Affidavit, hereby deposes and states, to the best of his or her personal knowledge and belief as follows:

#### **Terms:**

- A. "Northeast Texas Community College District" and "NTCC" are synonymous.
  - B. "Local Government Officer" and "NTCC Agent" are synonymous.
  - C. "Respondent", as used herein, includes the individual or business entity submitting the solicitation response and for the purpose of this Affidavit includes the directors, officers, partners, managers, members, principals, owners, agents, representatives, employees, other parties in interest of the Respondent, and anyone or any entity acting for or on behalf of the Respondent including a subcontractor in connection with this solicitation.
  - D. "Conflicts of Interest Questionnaire" <https://www.ethics.state.tx.us/forms/CIQ-New-2015.pdf> (Exhibit C-2)
  - E. "NTCC Agent" as used herein, includes the individual(s) for the purpose of this Affidavit includes:
    - Board of Trustees
    - President
    - Executive Vice President
    - Vice Presidents
    - Employees in the Business Office/Unit
    - Employees in the Facilities and Construction department/unit; and
    - Employees with direct or indirect participation in the Solicitation process.
1. **Anti-Collusion Statement.** The Respondent has not and will not in any way directly or indirectly:
    - a. Colluded, conspired, or agreed with any other person, firm, corporation, respondent or potential respondent the amount of this solicitation response or the terms or conditions of this solicitation response.
    - b. Paid or agreed to pay any other person, firm, respondent or potential respondent any money or anything of value in return for assistance in procuring or attempting to procure a contract or in return for establishing the prices in the attached response or the response of any other respondent.
  2. **Preparation of the Solicitation and Contract Documents.** The Contractor has not received any compensation or a promise of compensation for participating in the preparation or development of the underlying solicitation or contract documents., In addition, the Contractor has not otherwise participated in the preparation or development of the underlying solicitation or contract documents, except to the extent of any comments or questions and responses in the solicitation process, which are available to all Contractors, so as to have an unfair advantage over other Contractors, provided that the Contractor may have provided relevant product or process information to a consultant in the normal course of its business.
  3. **Participation in Decision Making Process.** The Contractor has not participated in the evaluation of

responses or responses or other decision making process for this solicitation, and, if Respondent is awarded a contract hereunder, no individual, agent, representative, consultant or sub-contractor or consultant associated with Respondent, who may have been involved in the evaluation or other decision making process for this solicitation, will have any direct or indirect financial interest in the Contract, provided that the Respondent may have provided relevant product or process information to a consultant in the normal course of its business.

4. **Present Knowledge.** Respondent is not presently aware of any potential or actual conflicts of interest regarding this solicitation, which either enabled Respondent to obtain an advantage over other Respondents or would prevent Respondent from advancing the best interests of NTCC in the course of the performance of the Contract.
5. **Purchasing Rules.** No individual with substantial interest in the Respondent's company is a NTCC agent or employee; and no individual with substantial interest in respondent's company is related to any NTCC agent of employee within the first, second or third degree of consanguinity (e.g., a parent, child, brother, sister, grandparent, etc.) or affinity.
6. **Chapter 176 Conflict of Interest Disclosure.** In accordance with Chapter 176 of the Texas Local Government Code, the Respondent:
  - a. does not have an employment or other business relationship with any local government officer of NTCC or a family member of that officer that results in the officer of family member receiving taxable income;
  - b. has not given a local government officer of NTCC one or more gifts, other than gifts of food lodging transportation or entertainment accepted as a guest, that have an aggregate value of more than \$50 in the twelve month period preceding the date the officer becomes aware of the execution of the Contract or that NTCC is considering doing business with the Respondent.

***As required by Chapter 176, Respondent must have filed a Conflicts of Interest Questionnaire with the Business Office no later than the seventh business day after the commencement of contract discussions or negotiations with the NTCC or the submission of a Solicitation response, response to a solicitation, or other writing related to a potential contract with NTCC. The questionnaire must be updated not later than the seventh day after the date of an event that would make a statement in the questionnaire inaccurate or incomplete. There are statutory penalties for failure to comply with Chapter 176.***

7. **Anti-Lobbying.** Between the date that the solicitation was issued and the date of full execution of the Contract, Respondent has not made and will not make a representation to a member of NTCC or NTCC Agent, other than the authorized contact person for the solicitation.

***If the Respondent cannot affirmatively swear and subscribe to the forgoing statements, the Respondent shall provide a detailed written explanation in the space provided below or, as necessary, on separate pages to be annexed hereto.***

**Signature:** \_\_\_\_\_ **Date:** \_\_\_\_\_

**Printed Name** \_\_\_\_\_

**Title** \_\_\_\_\_

**Firm/Entity** \_\_\_\_\_

**Respondent's Explanation:** \_\_\_\_\_

\_\_\_\_\_



## EXHIBIT C-2 of 2

<b>CONFLICT OF INTEREST QUESTIONNAIRE</b> <b>For vendor doing business with local governmental entity</b>	<b>FORM</b> <b>CIQ</b>
<p><b>This questionnaire reflects changes made to the law by H.B. 23, 84th Leg., Regular Session.</b> This questionnaire is being filed in accordance with Chapter 176, Local Government Code, by a vendor who has a business relationship as defined by Section 176.001(1-a) with a local governmental entity and the vendor meets requirements under Section 176.006(a).</p> <p>By law this questionnaire must be filed with the records administrator of the local governmental entity not later than the 7th business day after the date the vendor becomes aware of facts that require the statement to be filed. See Section 176.006(a-1), Local Government Code.</p> <p>A vendor commits an offense if the vendor knowingly violates Section 176.006, Local Government Code. An offense under this section is a misdemeanor.</p>	<p><b>OFFICE USE ONLY</b></p> <p>Date Received</p>
<p><input type="checkbox"/> <b>Name of vendor who has a business relationship with local governmental entity.</b></p>	
<p><input type="checkbox"/> <b>Check this box if you are filing an update to a previously filed questionnaire.</b></p> <p>(The law requires that you file an updated completed questionnaire with the appropriate filing authority no later than the 7th business day after the date on which you became aware that the originally filed questionnaire was incomplete or inaccurate.)</p>	
<p><input type="checkbox"/> <b>Name of local government officer about whom the information in this section is being disclosed.</b></p> <p style="text-align: center;">_____</p> <p style="text-align: center;"><b>Name of Officer</b></p> <p>This section (item 3 including subparts A, B, C, &amp; D) must be completed for each officer with whom the vendor has an employment or other business relationship as defined by Section 176.001(1-a), Local Government Code. Attach additional pages to this Form CIQ as necessary.</p> <p>A. Is the local government officer named in this section receiving or likely to receive taxable income, other than investment income, from the vendor?</p> <p style="text-align: center;"><input type="checkbox"/> <b>Yes</b>      <input type="checkbox"/> <b>No</b></p> <p>B. Is the vendor receiving or likely to receive taxable income, other than investment income, from or at the direction of the local government officer named in this section AND the taxable income is not received from the local governmental entity?</p> <p style="text-align: center;"><input type="checkbox"/> <b>Yes</b>      <input type="checkbox"/> <b>No</b></p> <p>C. Is the filer of this questionnaire employed by a corporation or other business entity with respect to which the local government officer serves as an officer or director, or holds an ownership interest of one percent or more?</p> <p style="text-align: center;"><input type="checkbox"/> <b>Yes</b>      <input type="checkbox"/> <b>No</b></p> <p>D. Describe each employment or business and family relationship with the local government officer named in this section.</p>	

# N **NORTHEAST TEXAS** COMMUNITY COLLEGE

NORTHEAST TEXAS COMMUNITY COLLEGE  
 CARROLL SHELBY BUILDING ADDITION  
 2886 FM 1735  
 Mount Pleasant, Texas 75455  
 SEPTEMBER 2, 2021



**PROJECT OWNER**

NORTH EAST TEXAS  
 COMMUNITY COLLEGE  
 2886 FM 1775  
 Mt. Pleasant, TX 75455  
 903.434.8115  
 Dr. Jon McCullough

**PROGRAM MANAGER &  
 STRUCTURAL ENGINEER**

Priefert Complex Designs, LLC  
 2630 S. Jefferson.  
 Mt. Pleasant, TX 75455  
 800.527.8616  
 Jeffery Boone

**GEOTECHNICAL**

GeoConsultants, LLC  
 170 Page Creek Dr.  
 Hallsville, TX 75650  
 903.235.6021  
 Gail Lewis, P.E.

**INDEX OF DRAWINGS**

**CIVIL**

---

C1.01 GRADING & DRAINAGE PLAN  
 C1.02 PAVING PLAN

**DEMOLITION**

---

D1.01 DEMO PLAN

**ARCHITECTURAL**

---

A1.01 FLOOR PLAN & ELEVATIONS

**STRUCTURAL**

---

S0.01 GENERAL NOTES & TYP DETAILS  
 S1.01 FOUNDATION PLAN & DETAILS  
 S2.01 FRAMING PLAN

**ELECTRICAL**

---

E1.01 LIGHTING & SWITCH PLAN

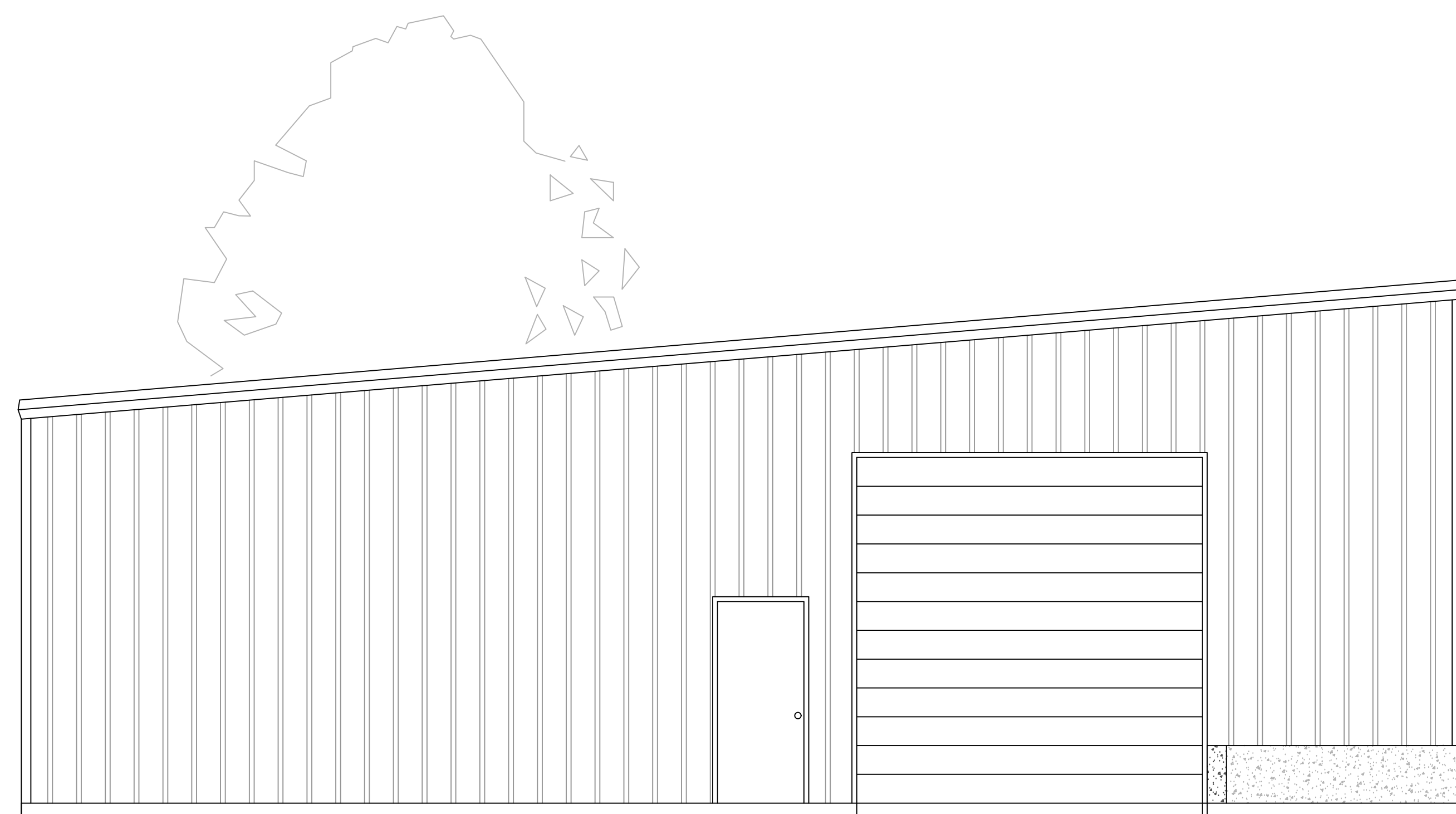

PROJECT LOCATION



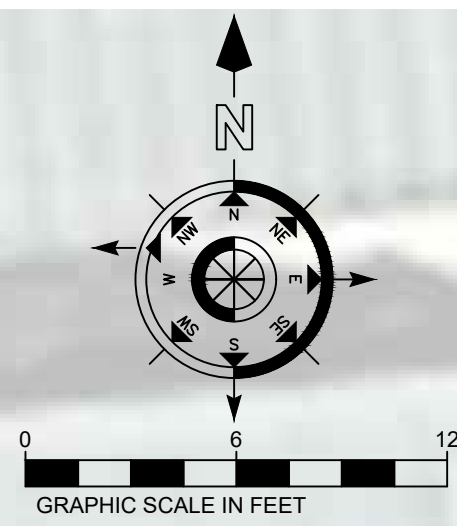

**N.T.C.C. SHELBY AUTOMOTIVE  
 BUILDING ADDITION**  
 MOUNT PLEASANT, TEXAS

**GRADING & DRAINAGE  
 PLAN**

NO.	DESCRIPTION	DATE
JOB NO: 2143	SHEET ISSUE DATE: 09-02-21	
PROJECT STATUS: FOR BIDDING & CONSTRUCTION		
SHEET NO.:		REVISION:
<b>C 1.01</b>		

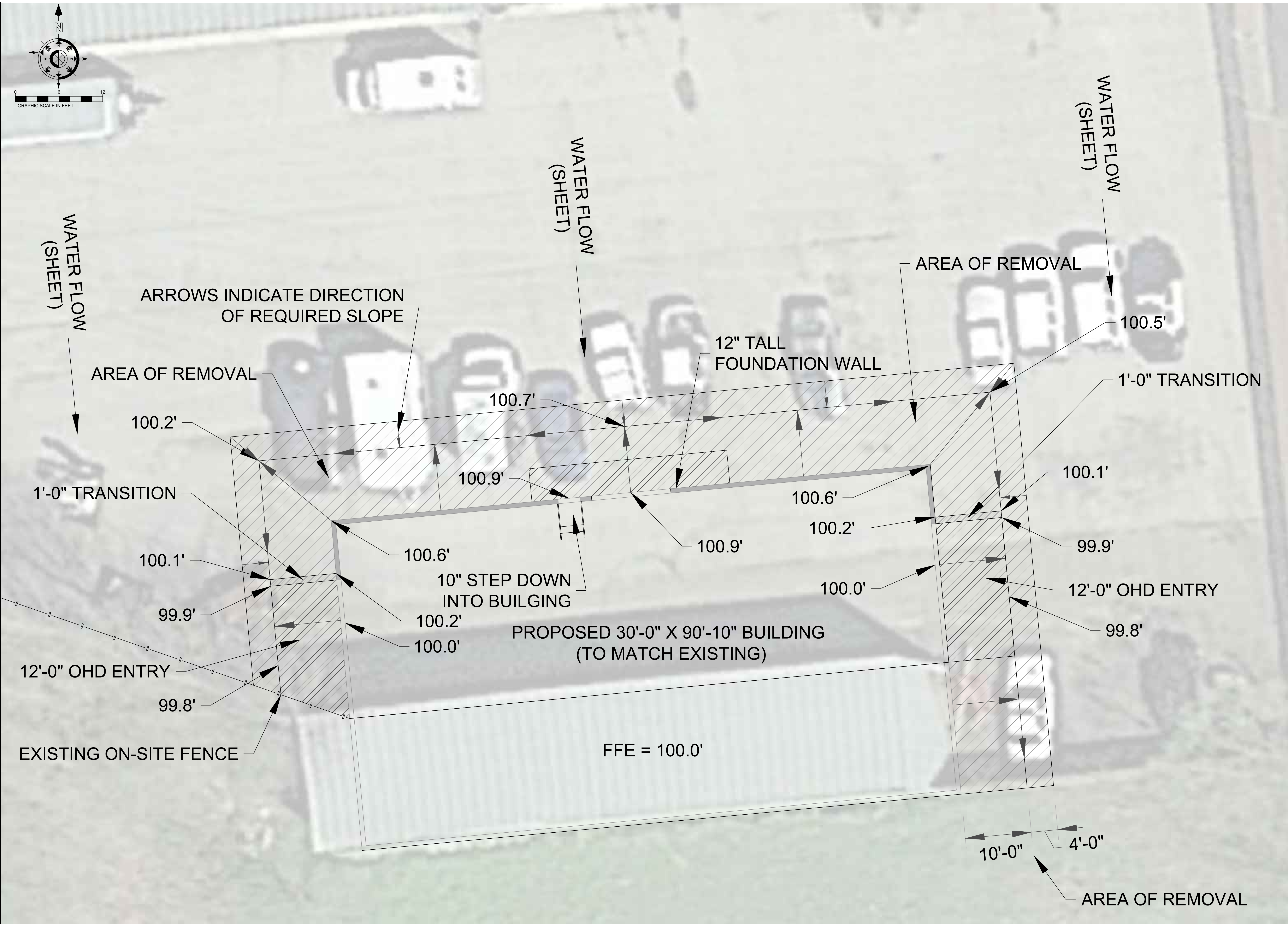

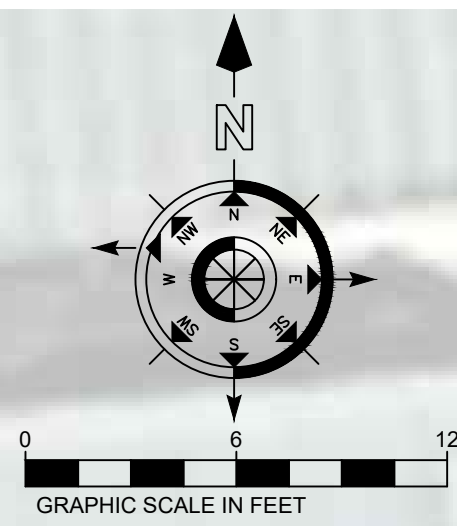

1 FT WIDE TRENCH PATCHED W/  
ASPHALT SHOWN IN  
APPROXIMATE LOCATION FOR  
UNDERGROUND POWER SUPPLY,  
PROVIDE ADDITIONAL 2" PVC  
CONDUIT W/ PULL STRING

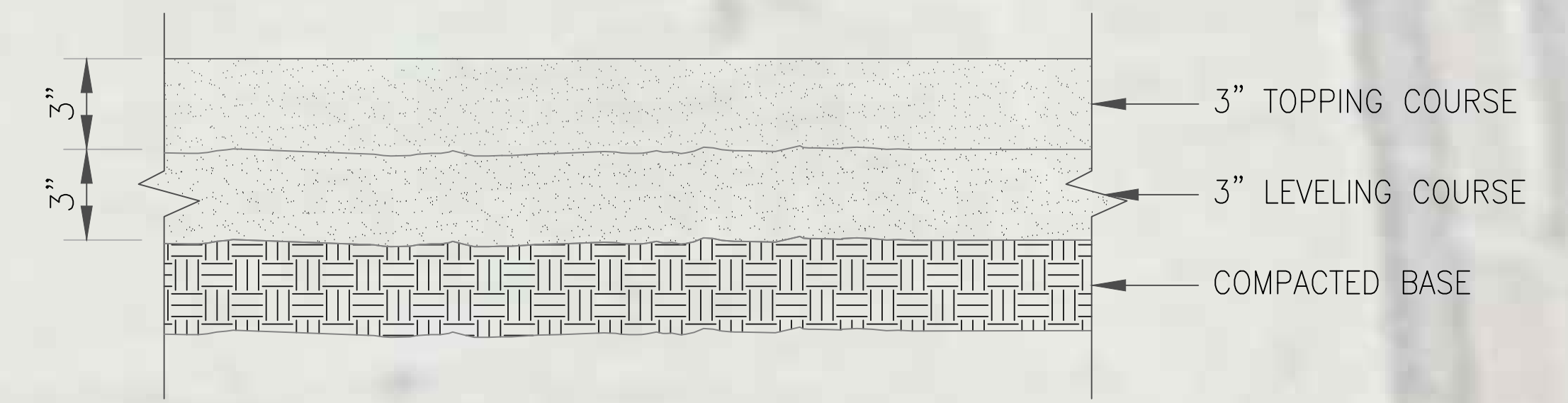

1 TYPICAL ASPHALT SECTION

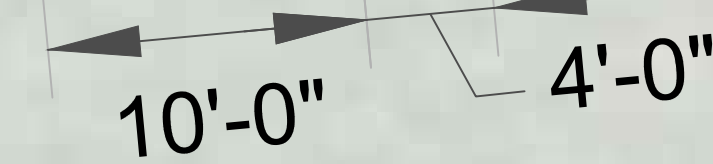
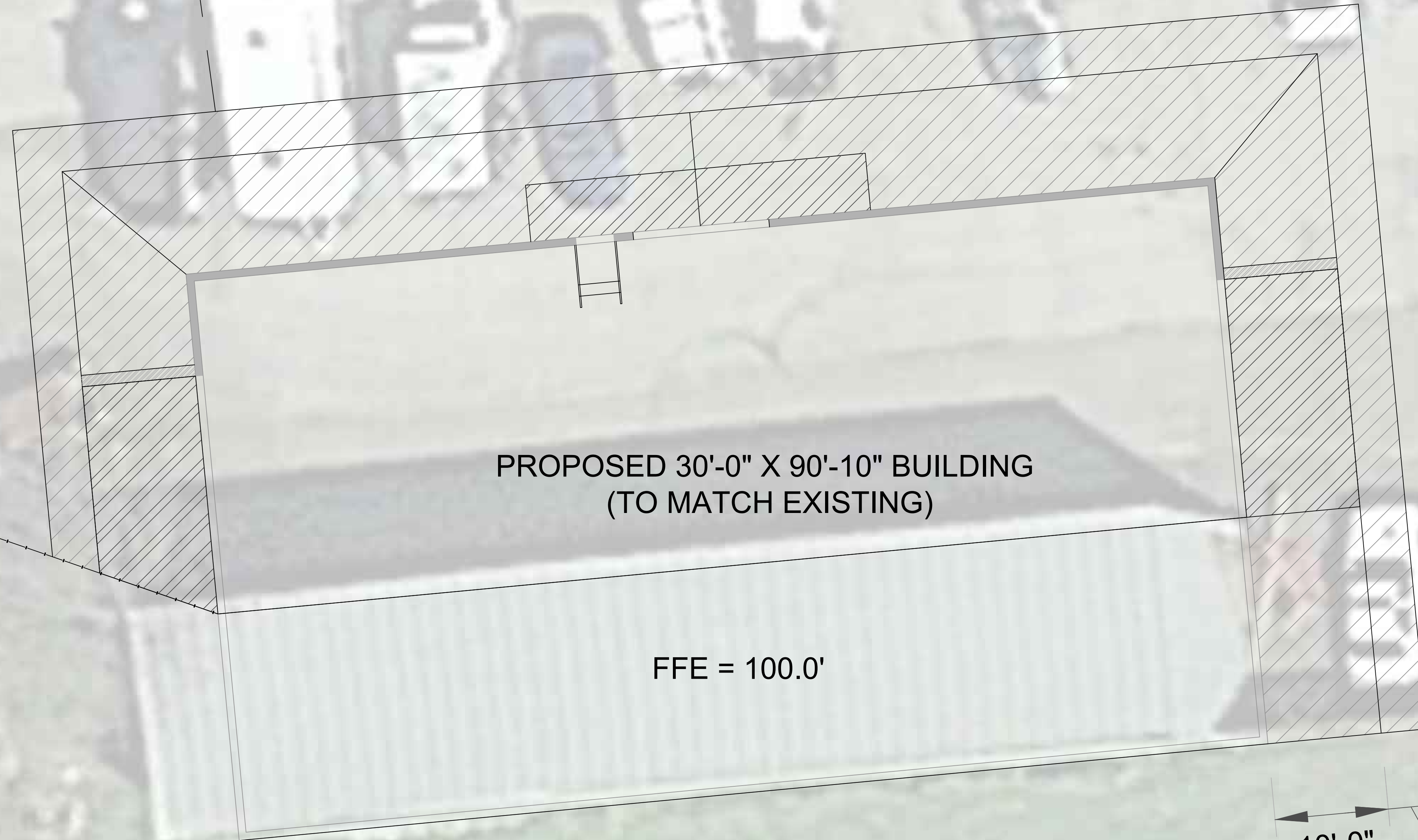

NO.	DESCRIPTION	DATE

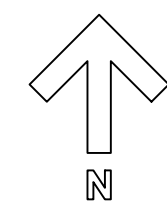
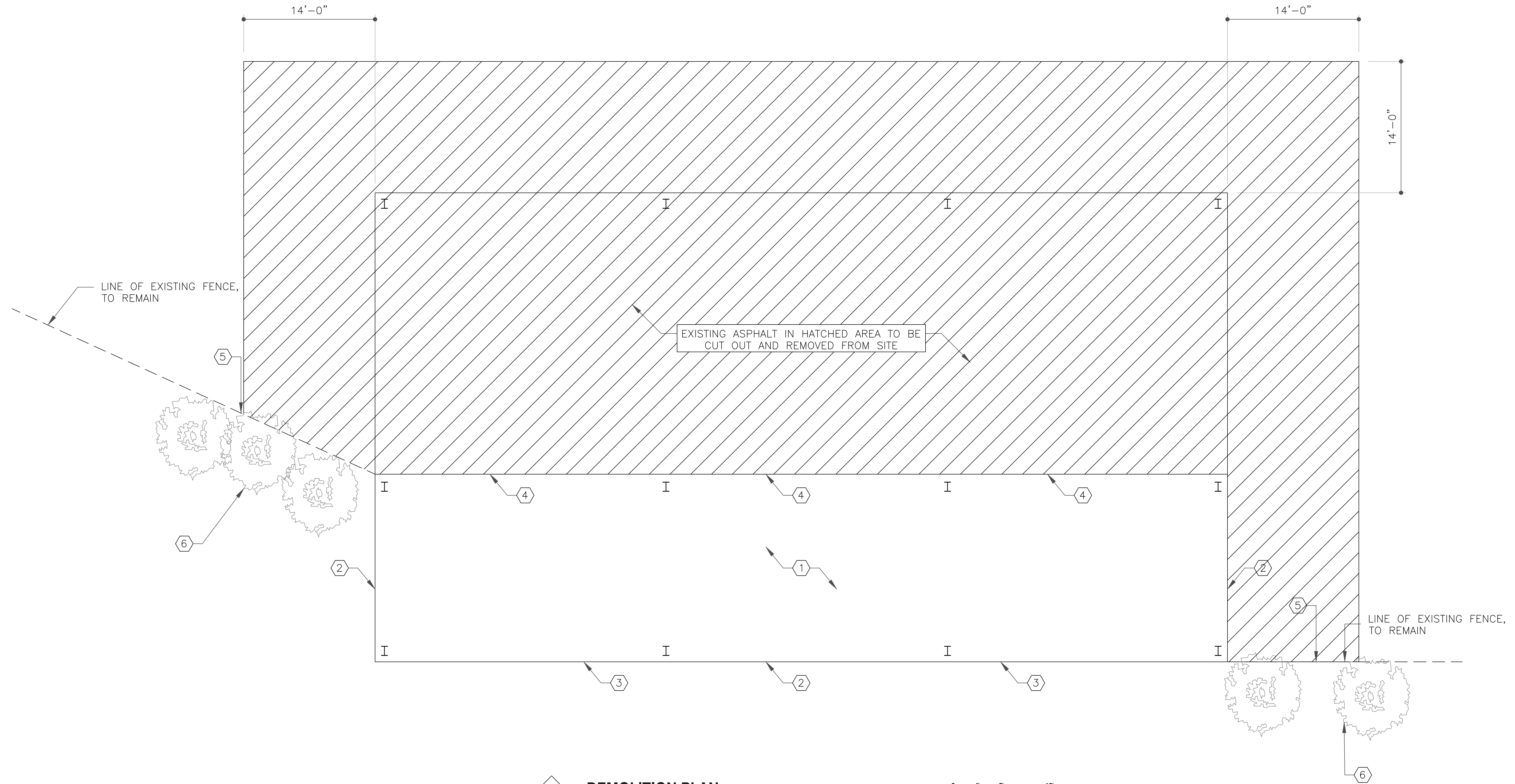

**DEMOLITION PLAN**

TOP OF CONCRETE AT ELEVATION 100'-0" UNLESS OTHERWISE NOTED BY (+) OR (-).

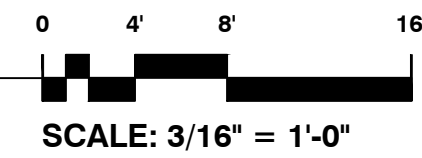

**KEYED NOTES:**

- ① REMOVE ROOF PANEL
- ② REMOVE WALL PANEL
- ③ REMOVE GUTTER
- ④ REMOVE WALL SKIRT, SHEETING AND GIRTS TO EAVE STRUT
- ⑤ INCREASE OPENING IN CONCRETE CURB TO 3'-0" (MIN) FOR DRAINAGE
- ⑥ TREES AND BRUSH IN AREA TO BE CUT DOWN AND REMOVED FROM SITE

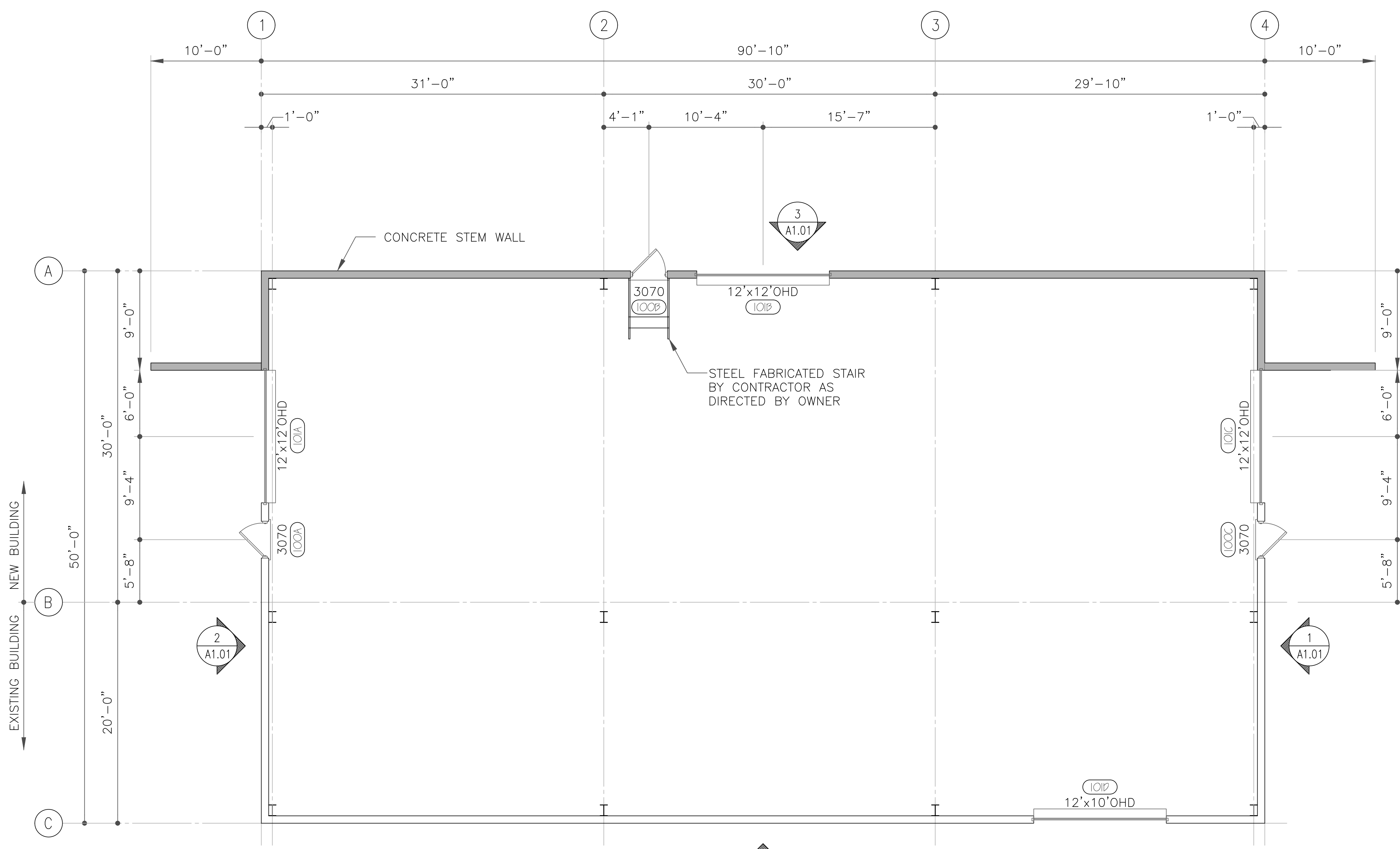

**FLOOR PLAN**  
 TOP OF CONCRETE AT ELEVATION 100'-0" UNLESS OTHERWISE NOTED BY (+) OR (-).  
 SCALE: 3/16" = 1'-0"

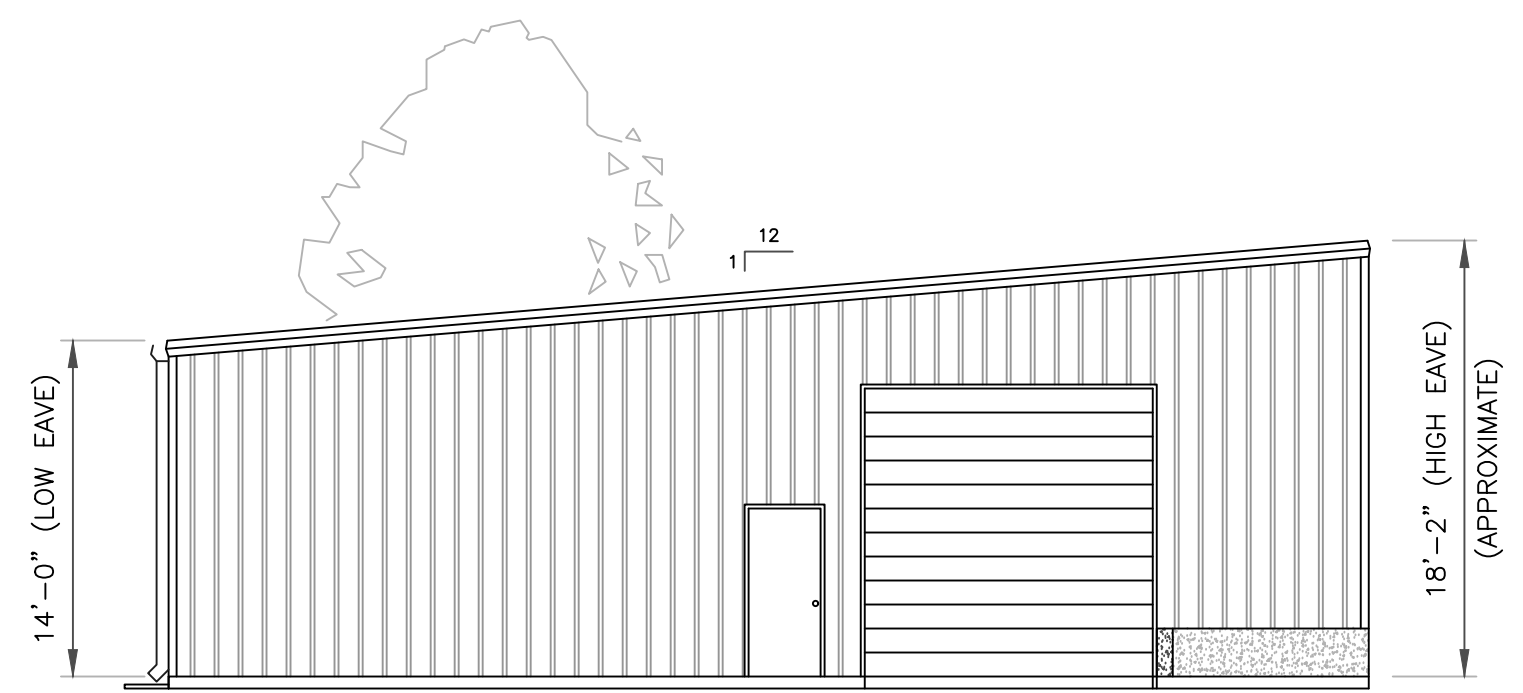

**1 EAST ELEVATION**  
 SCALE: 1/8" = 1'-0"

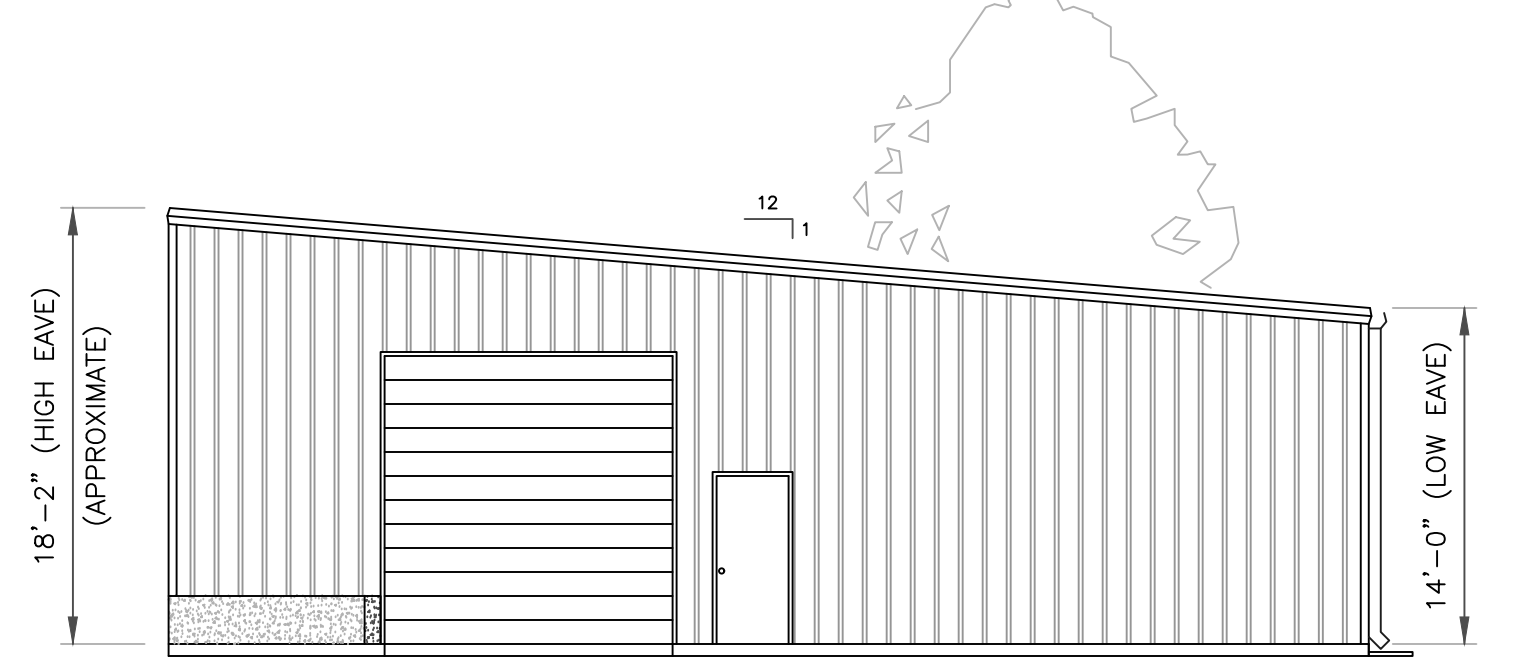

**2 WEST ELEVATION**  
 SCALE: 1/8" = 1'-0"

- DOOR HARDWARE:**
- CH CONTINUOUS HINGE
  - CL CLOSER; SURFACE MOUNTED, ADA COMPLIANT (INTEGRAL ON STOREFRONT DOORS)
  - ED EXIT DEVICE (PANIC BAR)
  - KP KICK PLATE
  - KC KEYED CYLINDER - MORTISE OR TAPERED BASED ON ASSEMBLY
  - LE LOCK SET - ENTRANCE FUNCTION (ANSI F109), KEYED, LEVER-HANDLE
  - LO LOCK SET - OFFICE FUNCTION (ANSI F82), KEYED, LEVER-HANDLE
  - LP LATCH SET - PASSAGE FUNCTION (ANSI F75) LEVER-HANDLE
  - LS LOCK SET - STOREROOM FUNCTION (ANSI F86), KEYED, LEVER-HANDLE
  - LR LOCK SET - PRIVACY FUNCTION (ANSI F76A) LEVER-HANDLE
  - OP OPENER - CHAIN OPERATED
  - PP PULL PLATE - 3"x12" PLATE WITH PULL HANDLE
  - PU PUSH PLATE - 3"x12" PLATE
  - SS SOUND SEALS - CONTINUOUS SOUND ISOLATION GASKETING
  - TH THRESHOLD - ADA COMPLIANT AND FOR MOISTURE PROTECTION
  - WS WEATHERSTRIPPING - THERMAL AND MOISTURE PROTECTION GASKETING
  - MFR ALL HARDWARE NOT OTHERWISE LISTED IS PROVIDED BY THE MANUFACTURER

MARK	DOOR				FRAME			HARDWARE	COMMENTS
	WIDTH	HEIGHT	MATERIAL	FINISH	MATERIAL	FINISH			
100A	3'-0"	7'-0"	HOLLOW METAL	PAINT	HOLLOW METAL	PAINT	CL,ED,KP,LO,TH,WS,MFR	SOLID PANEL DOOR (INSULATED)	
100B	3'-0"	7'-0"	HOLLOW METAL	PAINT	HOLLOW METAL	PAINT	CL,ED,KP,LO,TH,WS,MFR	SOLID PANEL DOOR (INSULATED)	
100C	3'-0"	7'-0"	HOLLOW METAL	PAINT	HOLLOW METAL	PAINT	CL,ED,KP,LO,TH,WS,MFR	SOLID PANEL DOOR (INSULATED)	
101A	12'-0"	12'-0"	OVERHEAD DOOR	PAINT	HOLLOW METAL	PAINT	OP, MFR	SOLID PANEL DOOR (INSULATED)	
101B	12'-0"	12'-0"	OVERHEAD DOOR	PAINT	HOLLOW METAL	PAINT	OP, MFR	SOLID PANEL DOOR (INSULATED)	
101C	12'-0"	12'-0"	OVERHEAD DOOR	PAINT	HOLLOW METAL	PAINT	OP, MFR	SOLID PANEL DOOR (INSULATED)	
101D	12'-0"	10'-0"	OVERHEAD DOOR	PAINT	HOLLOW METAL	PAINT	OP, MFR	SOLID PANEL DOOR (INSULATED)	

**5 FINISHES & SCHEDULES**

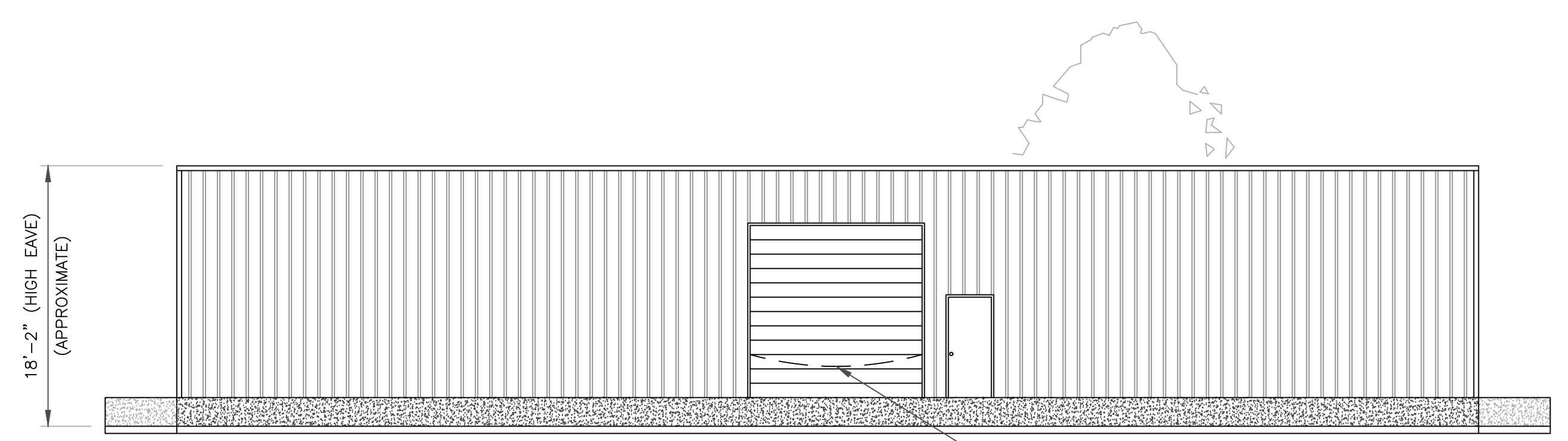

**3 NORTH ELEVATION**  
 SCALE: 1/8" = 1'-0"

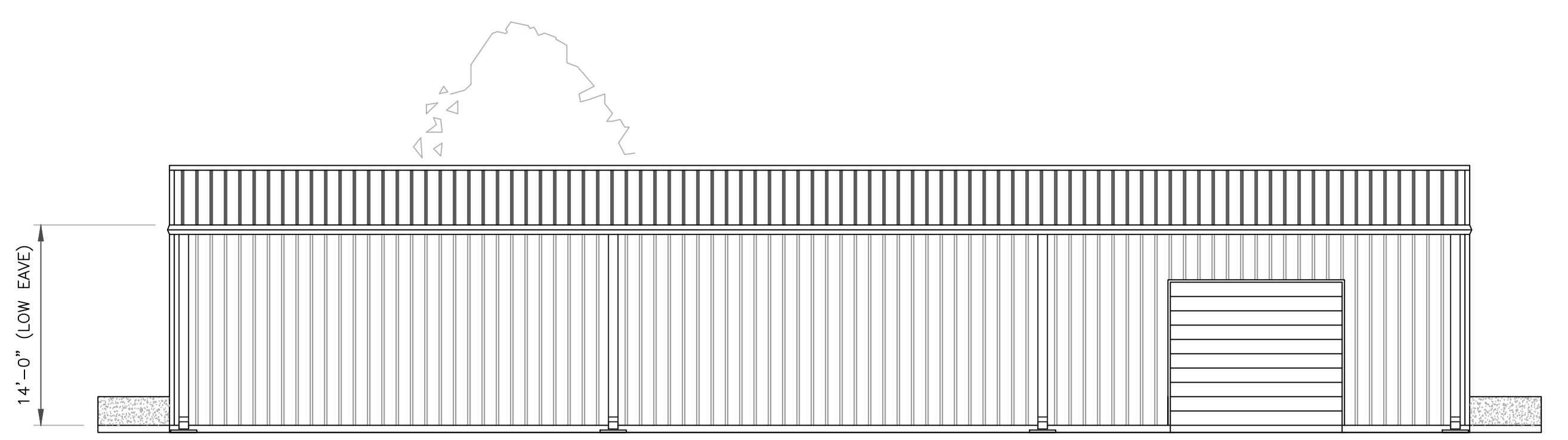

**4 SOUTH ELEVATION**  
 SCALE: 1/8" = 1'-0"

MISCELLANEOUS NOTES

- 1. These drawings are issued to indicate the general scope of the project in terms of the structural design concept, the dimensions of the building, the type of structure and the outline notes of the major structural elements of construction.
2. Contractor is to furnish all items required for proper completion of the work without adjustment to contract price.
3. The details designated as "Typical Details" apply generally to the drawings in areas where conditions are similar to those described in the details, unless noted otherwise.
4. All dimensions shall take precedence over scale shown on plans, sections and details.
5. Principal openings, curbs and slab depressions are shown on the drawings.
6. The contractor shall compare the structural drawings with the architectural, mechanical, electrical, plumbing and civil drawings to confirm all requirements of the work.
7. The contractor shall insure that all construction loads do not exceed the design live loads indicated on the structural drawings and that these loads are not put on the structural members prior to the time that the framing members, bracing members and connectors are in place.
8. The contractor is responsible for all temporary bracing and shoring required for completion of the work.
9. The contractor is responsible for the means and methods employed for the completion of the project.
10. The contractor shall obtain all permits necessary for completion of the work.
11. The contractor shall arrange all required inspections.

DESIGN CRITERIA NOTES

- 1. The structural design is in accordance with the 2015 International Building Code.
2. Design live loads are as listed below:
i. Collateral loads 7 psf
ii. Roofs 20 psf (reducible)
3. Design wind loads are in accordance with ASCE 7-10. Design assumptions are as follows:
iii. Basic wind speed 115 mph
ii. Wind exposure Exposure C
4. Design snow loads are in accordance with ASCE 7-10. Design assumptions are as follows:
i. Ground snow load 5 psf
ii. Fully exposed
iii. Heated
5. Seismic design loading criteria are as follows:
i. Ss 12.30%
ii. S1 6.70%

SHOP DRAWINGS

- 1. Contractor shall produce shop drawings for rebar, concrete mix designs, anchor bolt placement and structural steel.

FOUNDATION NOTES

- 1. The foundation is designed based on recommendations from GeoConsultants Project no. 2132 (the report). All work shall be in compliance with the recommendations contained in the reports.
2. Do not place underground utilities or pipes below footings.
3. Thoroughly compact the bottoms of footings and slab subgrade prior to placing any concrete.
4. All foundation design shall be based on final PEMB reactions provided by the contractor.
5. The below notes are currently pending at the time of this drawing due to sub-grade injection that will cause for re-testing of the soil properties to verify the final bearing capacity.
6. All foundation sizes shown in these drawings are based on preliminary reactions and assumed bearing capacities and shall be verified and revised before footing construction shall begin.

FOUNDATION SUBGRADE PREPARATION DEVELOPMENT NOTES

- 1. All topsoil, vegetation, roots and any soft soils in the building areas are to be stripped from the site.
2. Utilities should be located and rerouted as necessary.
3. After stripping the site, remove three (3) feet of the exposed subgrade and replace with compacted fill.
4. After stripping and undercutting, as required by the grading plan and over-excavating the building pad should be proof-rolled as required by the report.
5. Any weak area that yield under the proof-roll should be mitigated or modified with lime fly-ash.
6. The exposed soils should be scarified and then processed to a moisture content between three (1) percentage point below and three (3) percentage points above the optimum moisture content value and a minimum of 95% of the maximum dry density for a depth of at least (8) inches below the surface.

SELECT FILL NOTES

- 1. Select fill material should be free of organic or other deleterious, homogeneous mixture, have a liquid limit less than 35% and plasticity index between 8 and 20 and consist of silty-clayey sands (SM-SC), low plasticity sandy clays (CL), or clayey sands (SC).
2. Material should have less than 70 percent passing the no. 200 sieve.
3. Each lift of compacted soil should be tested and inspected by the soils engineer or his representative prior to placement of subsequent lifts. Two (2) tests per lift are recommended.
4. Positive drainage away from the structure should be provided at all times, including during construction.
5. Samples of the proposed fill materials should be obtained for laboratory moisture-density testing per the soil report.

SHALLOW FOUNDATIONS

- 1. Foundations have been designed based on the following capacities:
Allowable vertical foundation pressure 2,000 psf for spread footings wider than 2'-0"
Allowable vertical foundation pressure 1,500 psf for strip footings 1'-2" wide
2. Bottom of exterior footings shall be a minimum of 2'-0" below finished floor or 1'-6" below final grade.

SECONDARY DESIGN CONSIDERATIONS

- 1. Roof drainage should be routed via pipe or a hard surface at least 5 feet from the structure.
2. Pavements, sidewalks and the general ground surface should be sloped away from the structure on all sides.
3. Backfill for utility lines should be compacted to at least 95% of the standard compaction test.
4. Clayey sand fill has been specified for select fill to reduce the potential migration of water beneath the proposed establishment.
5. The depth of frost penetration in the vicinity of the project site is estimated to be approximately six inches.
6. Drainage details must focus on routing water away from the structure.
7. Landscaping elements, including irrigation systems must not be allowed to introduce excess water to the structure subgrade.
8. A vapor barrier shall be used under all portions of the slab.

STEEL NOTES

- 1. Structural steel shapes, plates, etc., shall conform to the following ASTM designations, U.N.O.
Floor/roof beams and girders ASTM A572-50
Columns ASTM A572-50
Channels, angles, bars ASTM A36
Steel tubing (TS Sections) ASTM A500-GR. B (Fy = 46 KSI)
Anchor Bolts: ASTM A449, U.N.O.
2. Connections
a. Connection bolts shall conform to ASTM A325. Use bearing type bolts with threads allowed across the shear plane.
b. Structural steel connection shall be AISC Bolted/Welded Double Angle Connections as prescribed by AISC Steel Construction Manual, 14th Edition, Table 10-2.
c. Structural steel shall be detailed, fabricated and erected in accordance with AISC specifications.
d. Bolt holds may be drilled or punched. Flame cut holes are not permitted.
3. Erector shall touch up primer paint at all field weld locations.
4. Provide steel beam connections as detailed on the drawings.

- 4. For all high strength bolts, hardened washers shall be provided.
5. Headed studs and deformed bar anchors used in fabrication of embedded assemblies shall be welded to those assemblies using a full fusion process.
6. Steel beams shall be erected with natural camber up.
7. Anchor bolts have not been designed for any specific erection forces.
8. Open web steel joists and bridging shall conform to the standards of the Steel Joist Institute.
9. If not shown on drawings, support of metal deck around column closure, screed plates around the openings and edge slab shall be provided by the contractor.
10. The contractor shall make safe provisions for stabilizing the steel structure both horizontally and vertically.
11. Structural steel beams are unrestrained for the purpose of establishing fireproofing rating.

12. Welding

- a. Welded construction shall conform to the American Welding Society "Structural Welding Code" D1.1: AWS D13-Steel (Steel); and AWS D1.4-"Reinforcing Steel Welding Code".
b. Electrodes for field and shop welds of structural steel shall be E70XX, U.N.O.
c. Electrodes for welding of reinforcing steel shall be E60XX.
d. Electrodes for welding of sheet steel shall conform to AWS D1.3.
e. When welds are not called-out on drawings, they are minimum size continuous fillet welds in accordance with AWS D1.1.
f. Unless noted otherwise on the drawings, all groove welds shall be full penetration.
g. Only low hydrogen electrodes shall be used on reinforcing steel and ASTM A572 steel.
h. Provide fillet welds at all contact joints between steel members sufficient to develop the allowable tensile strength of the smaller member at the joint unless detailed otherwise on the drawings.
i. Frame welding sequence: longitudinal shrinkage stresses due to field welding shall be minimized by making welded connections starting at the most central beams in each frame and processing toward the end columns in each frame.

CONCRETE NOTES

- 1. Minimum 28 day cylinder compressive strength of 3,000 psi, maximum water cement ratio of 0.45 and maximum slump of 4" prior to addition of superplasticizers.
2. Reinforcing steel ASTM a615, grade 60. Laps 42 diameters unless noted.
3. Detailing of concrete reinforcing bars and accessories shall conform to the recommendations of ACI-315, "details and detailing of concrete reinforcement" ACI SP-66 "detailing manual".
4. Minimum concrete cover protection for reinforcement bars shall be as follows:
footings: 3 inches (where exposed to earth)
grade beams: top: 1 1/2 inches
board formed sides: 2 inches
earth formed sides: 3 inches
bottom: 3 inches
concrete exposed to weather 2 inches
slabs on ground h/3 from top, not more than 2"

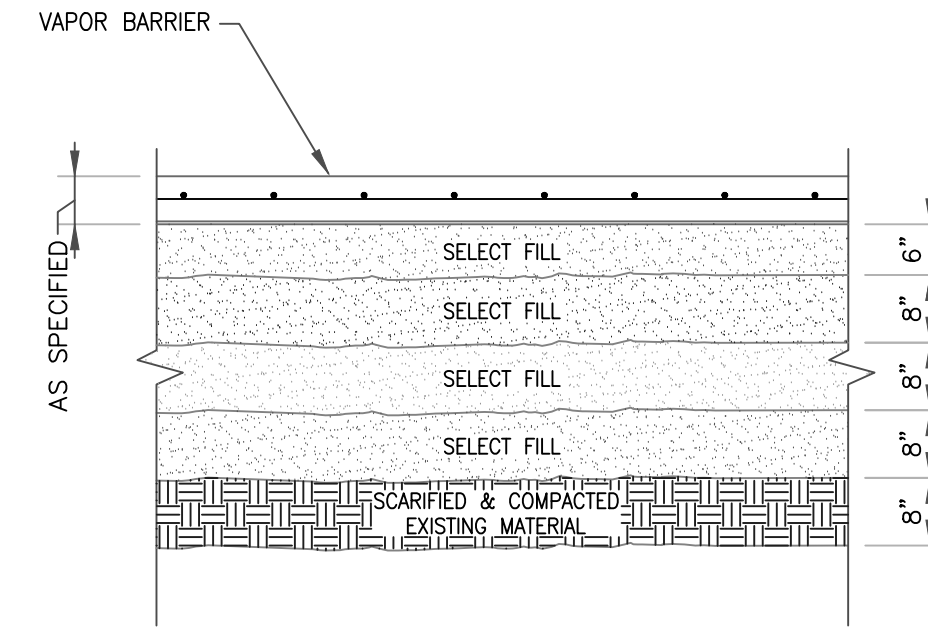

NOTES:

- 1. SELECT FILL PLACED ACCORDING TO GEOTECHNICAL REPORT.
2. NUMBER OF LIFTS BASED ON ACTUAL GRADE AND FINISHED FLOOR ELEVATIONS.
3. REFER TO PLANS FOR SLAB-ON-GRADE REQUIREMENTS
4. EXTEND PAD PREPARATION TO 5' OUTSIDE OF BUILDING LINES.

1 SUBGRADE PREPARATION SECTION

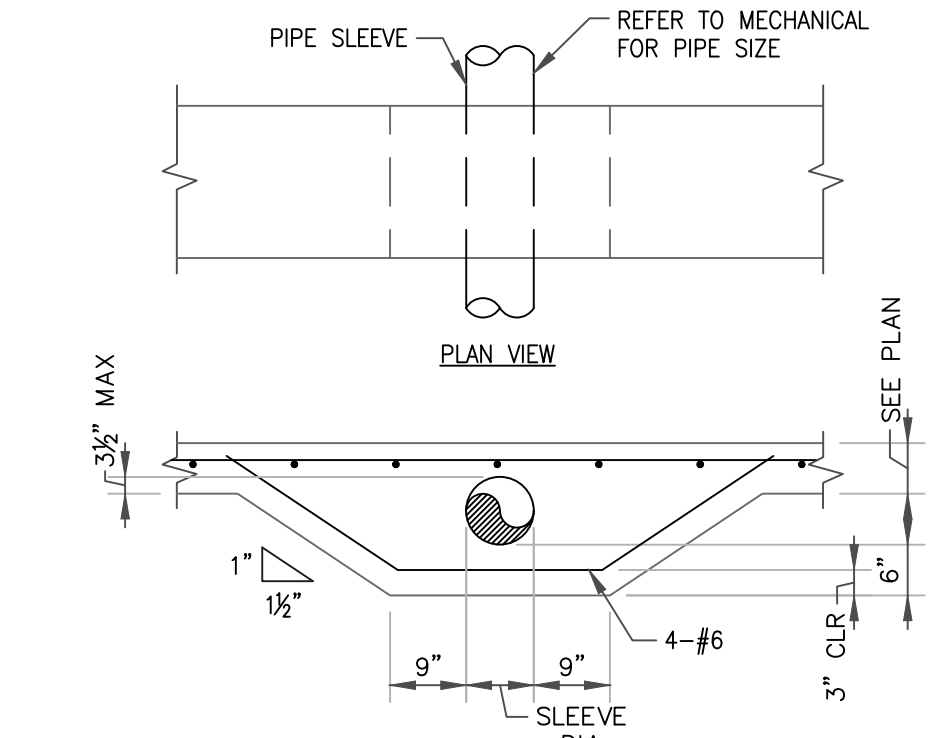

2 TYP DEEPENED BEAM @ PIPE SLEEVE

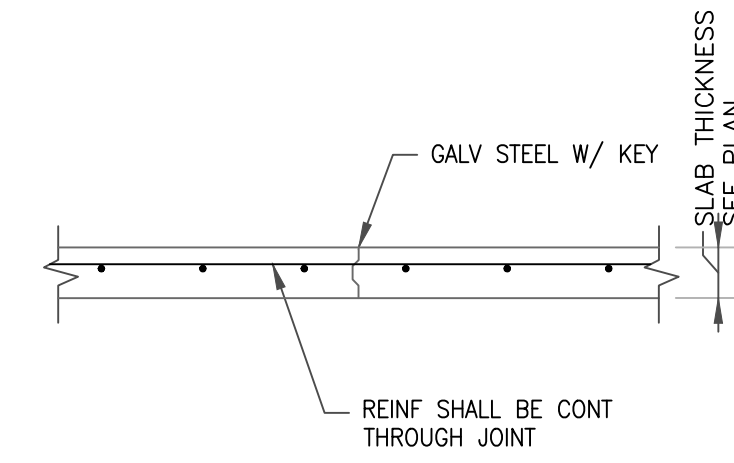

3 TYP SLAB CONSTRUCTION JOINT

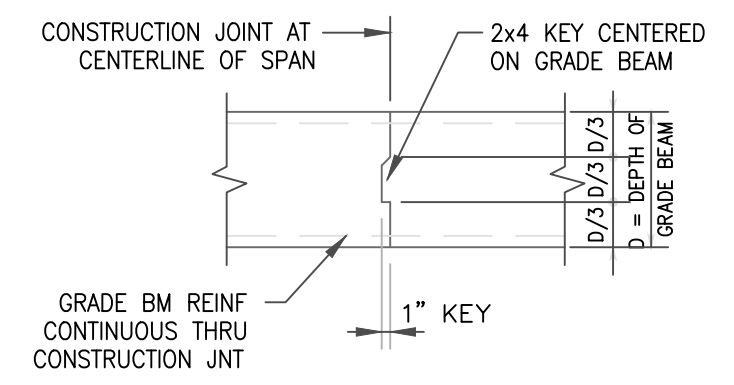

4 TYP GRADE BEAM CONSTRUCTION JOINT

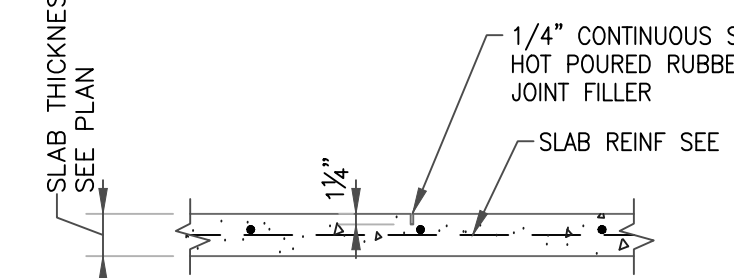

5 TYP SLAB CONTROL JOINT

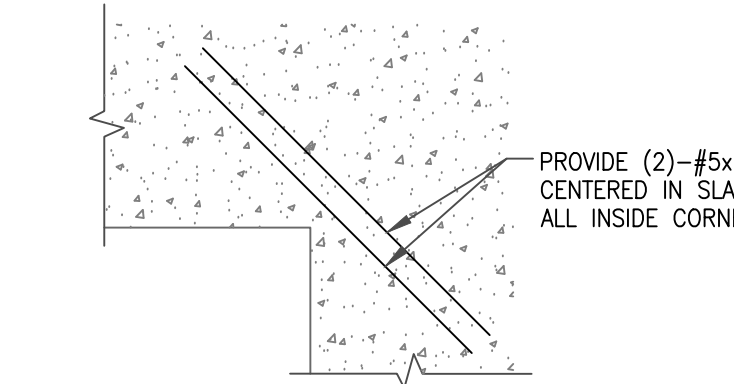

6 TYP SLAB ON GRADE REINFORCING

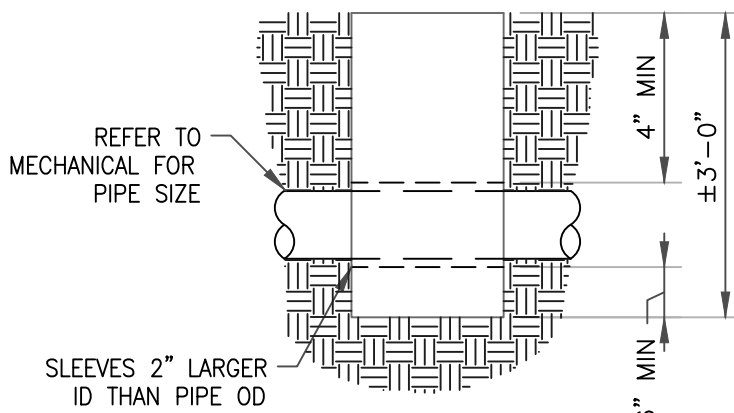

7 TYP PIPE SLEEVE THROUGH GRADE BEAM OR FOOTING

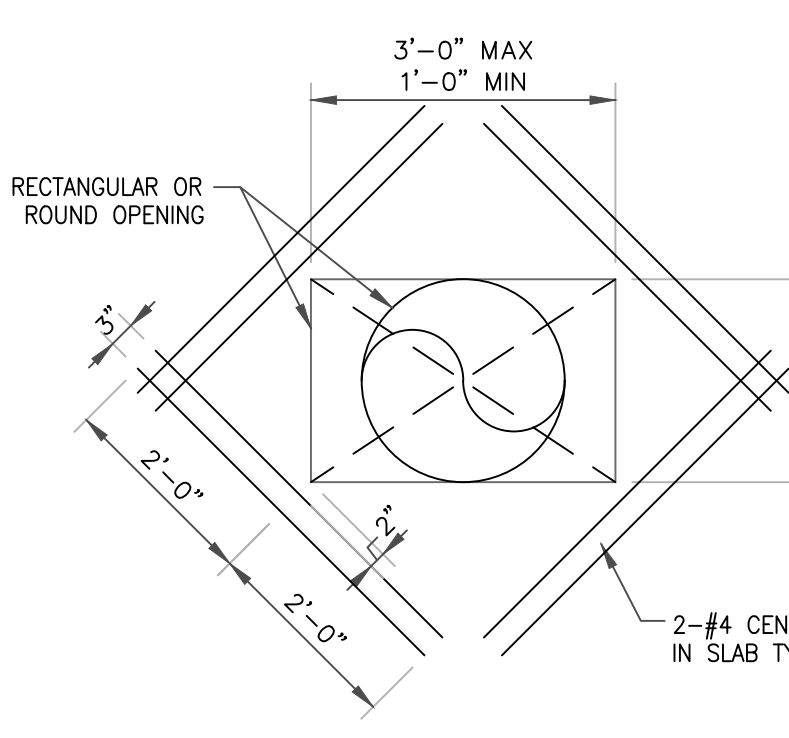

8 TYP OPENING IN SLAB ON GRADE

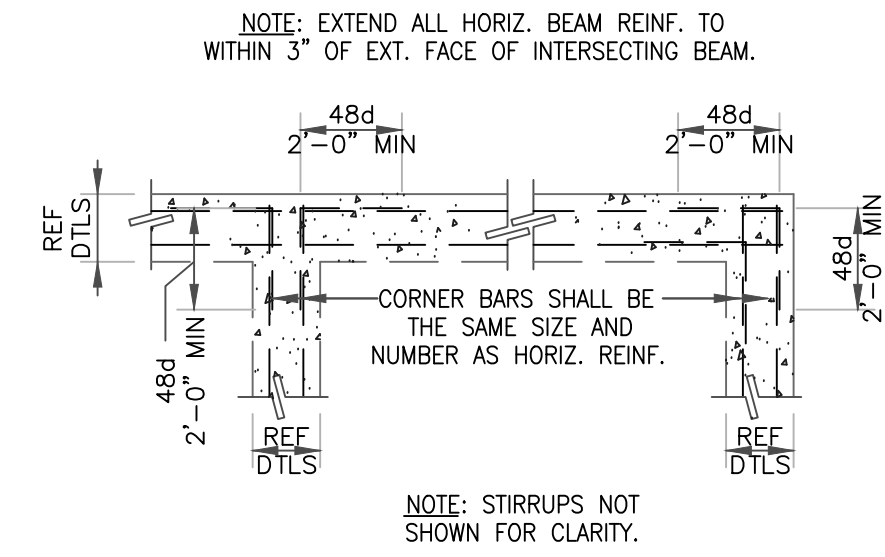

9 TYP GRADE BEAM CORNER BAR REINF.

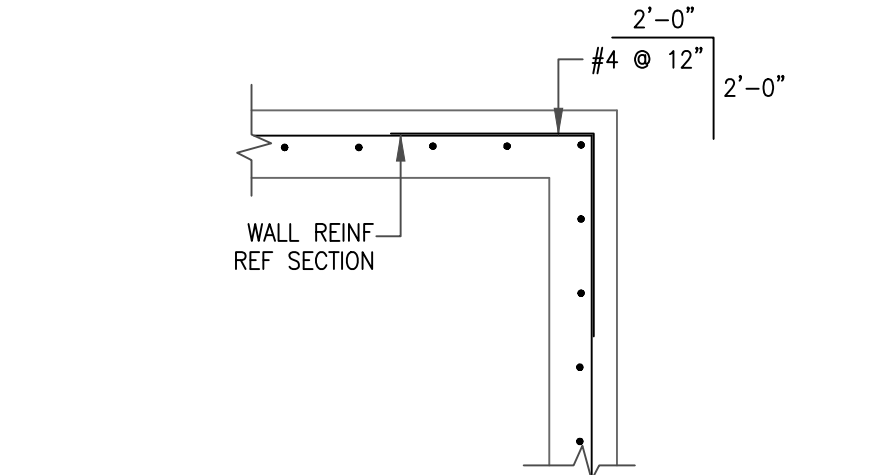

10 TYP. WALL INTERSECTION/CORNER

11

12

13

14

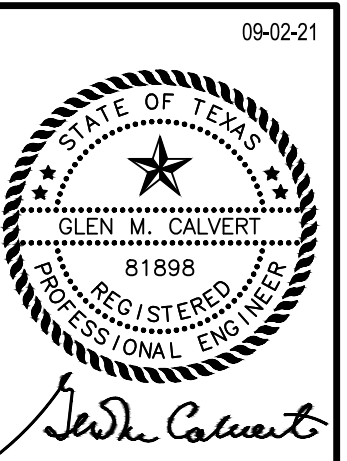
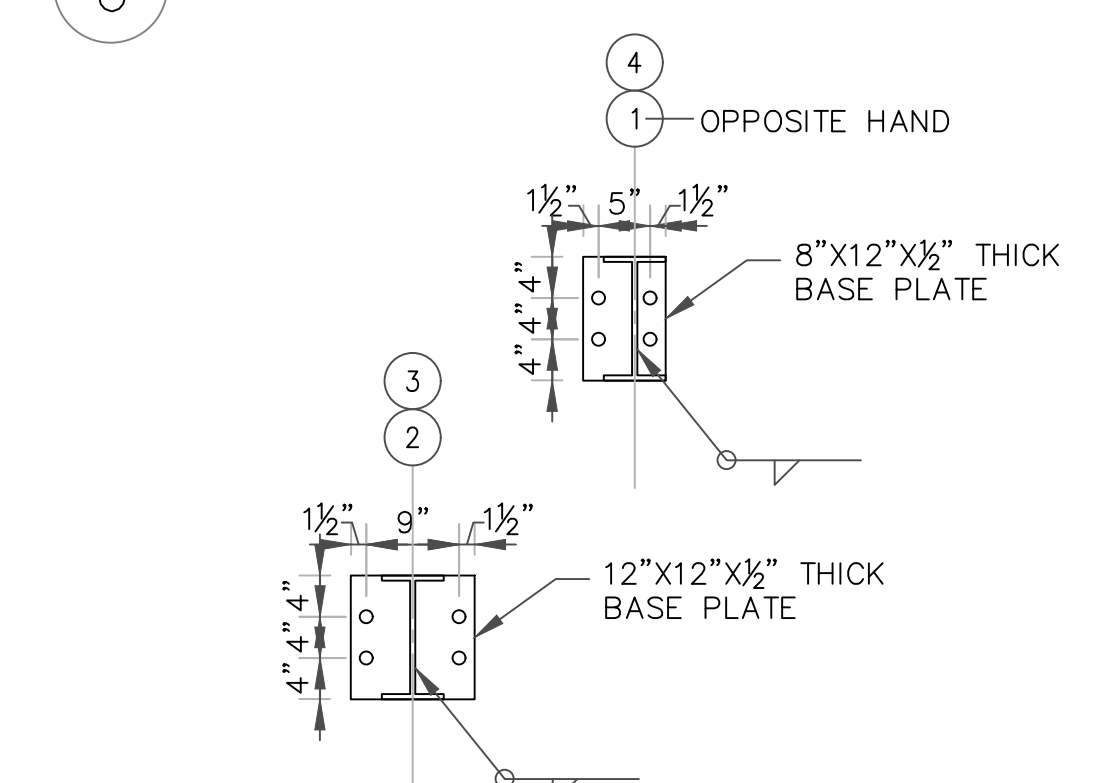
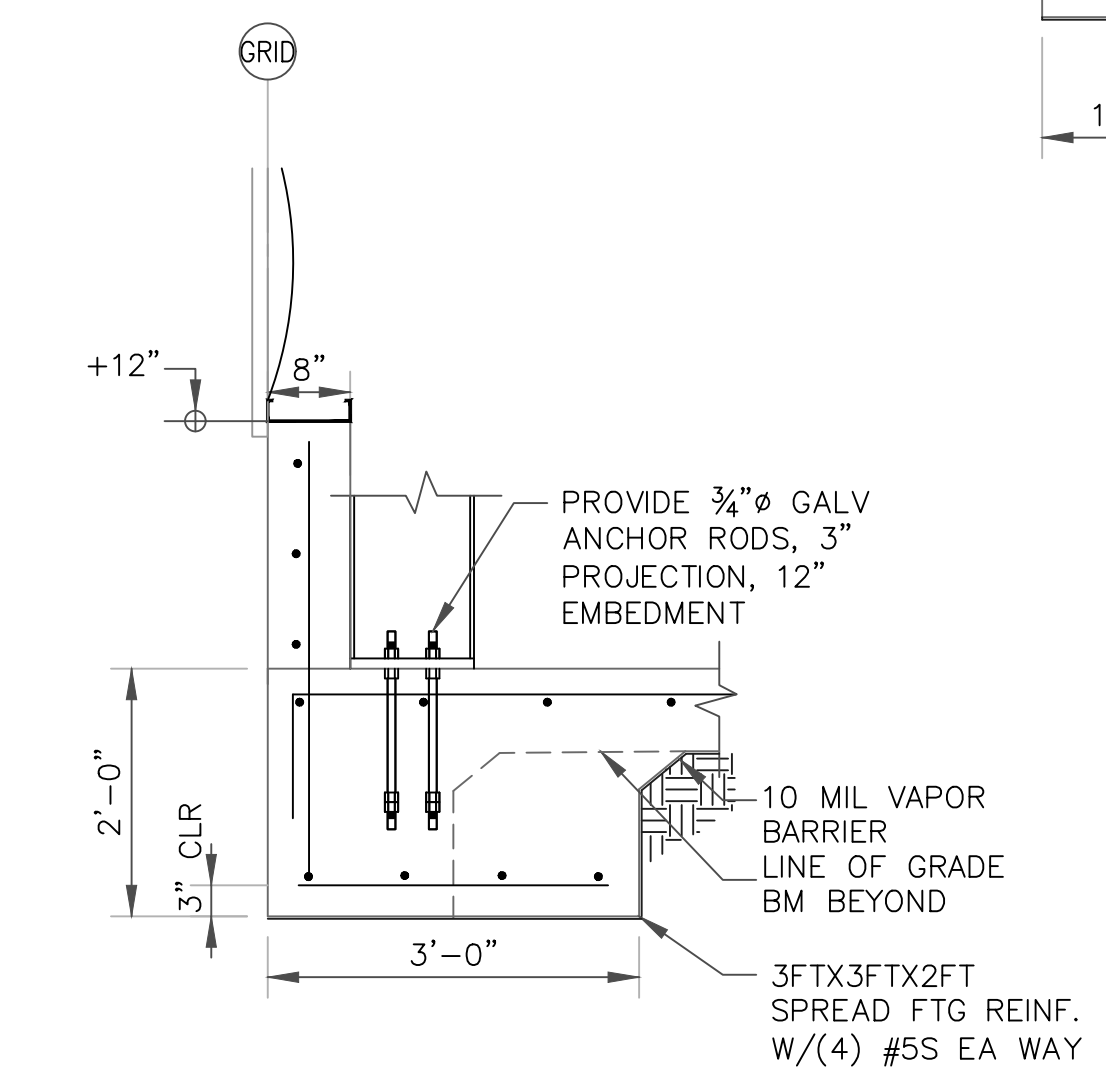
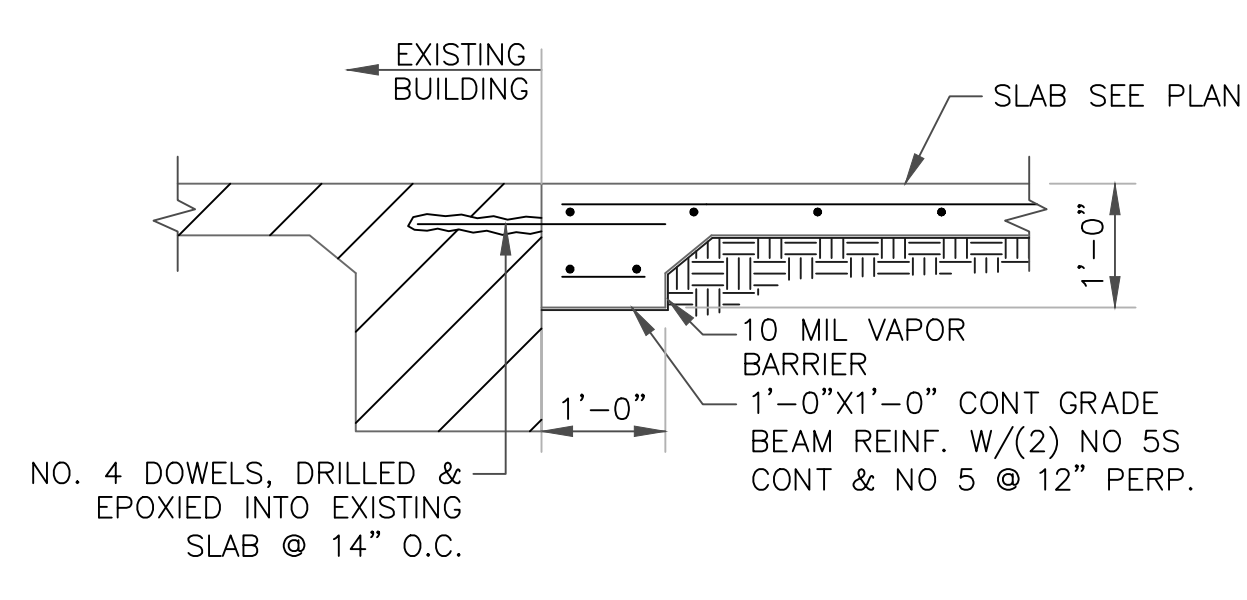
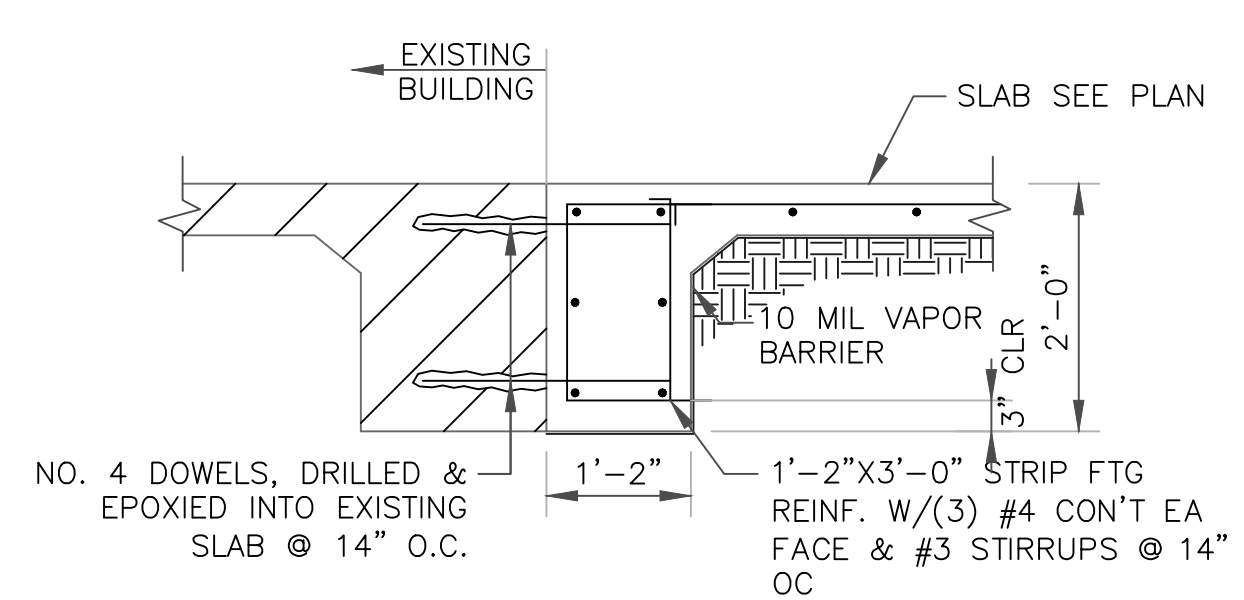
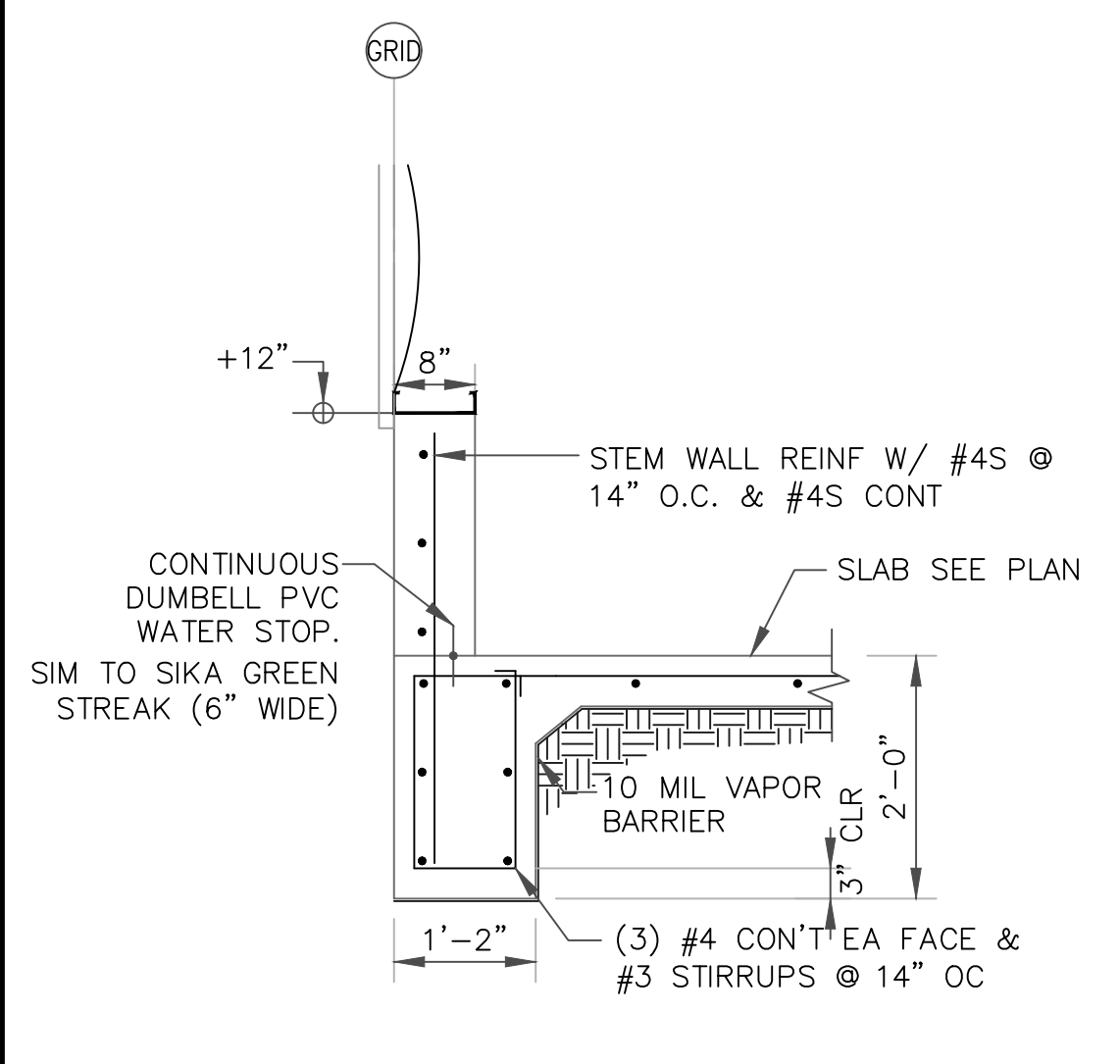
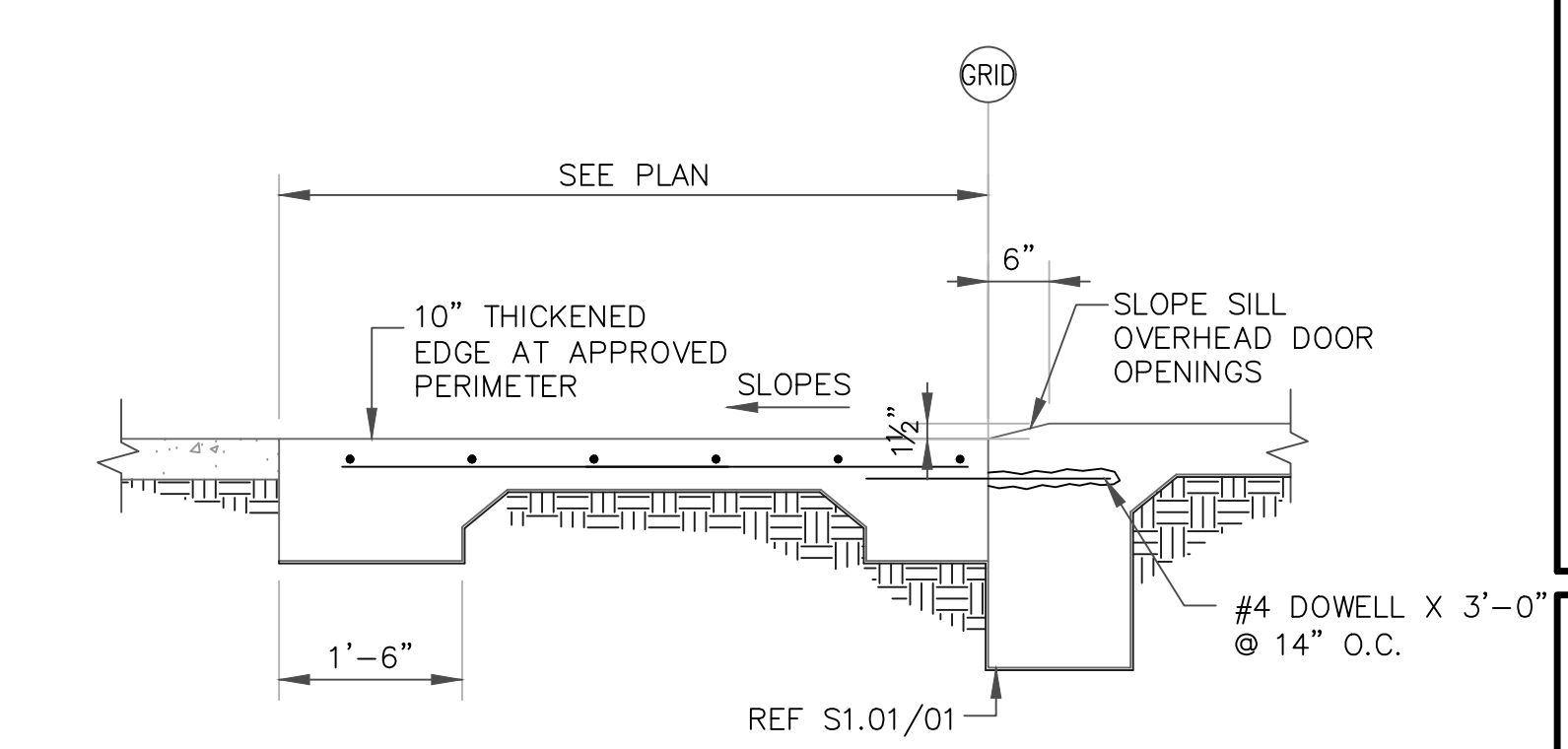
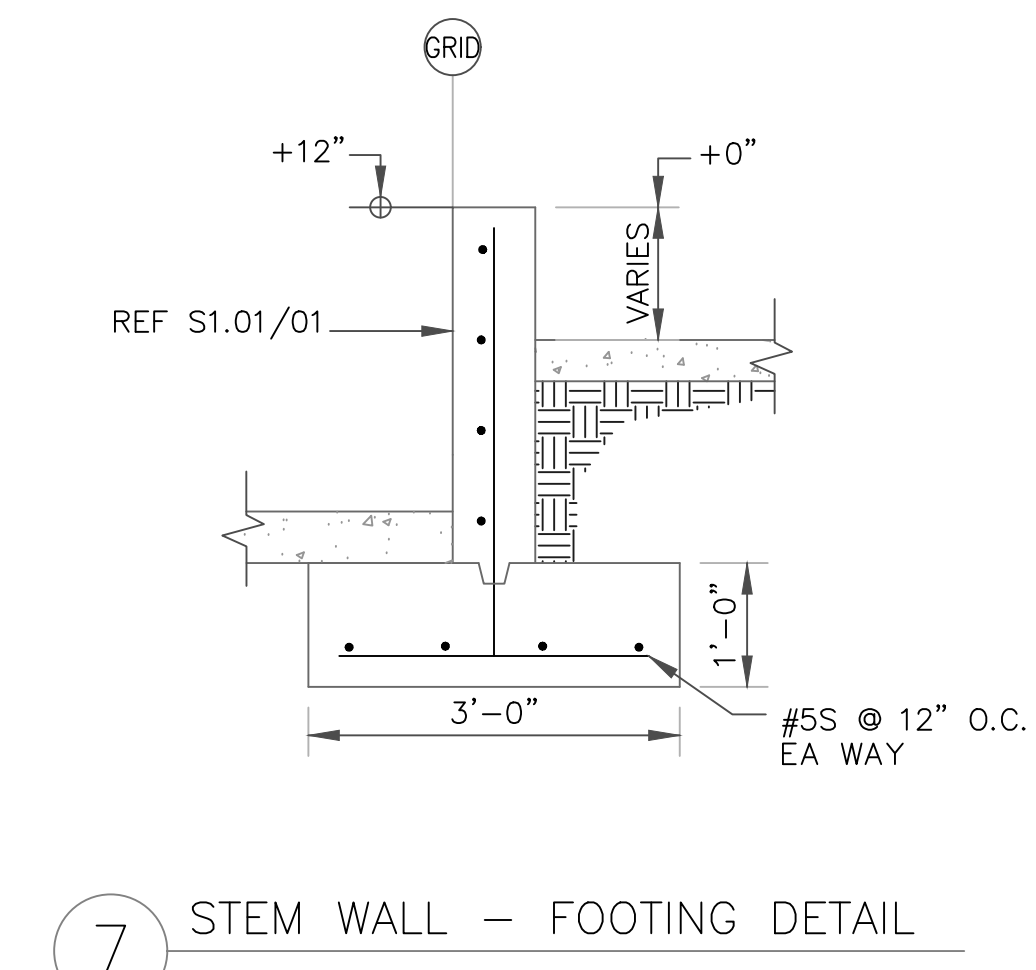
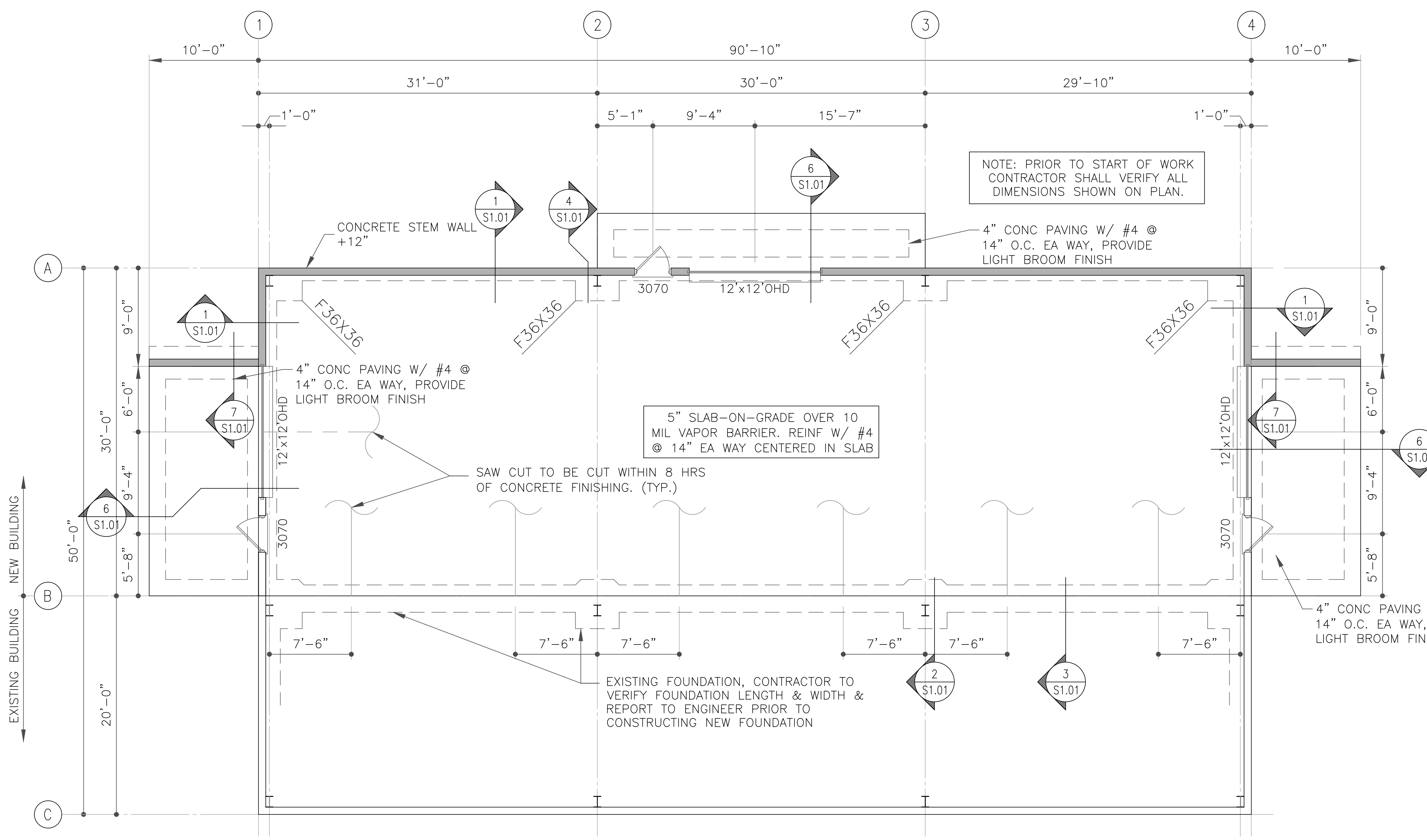

**N.T.C.C. SHELBY AUTOMOTIVE BUILDING ADDITION**  
 MOUNT PLEASANT, TEXAS

**FOUNDATION PLAN**

NO.	DESCRIPTION	DATE
JOB NO: 2143	SHEET ISSUE DATE: 09-02-21	
PROJECT STATUS: FOR BIDDING & CONSTRUCTION		
SHEET NO.:	REVISION:	

**S1.01**



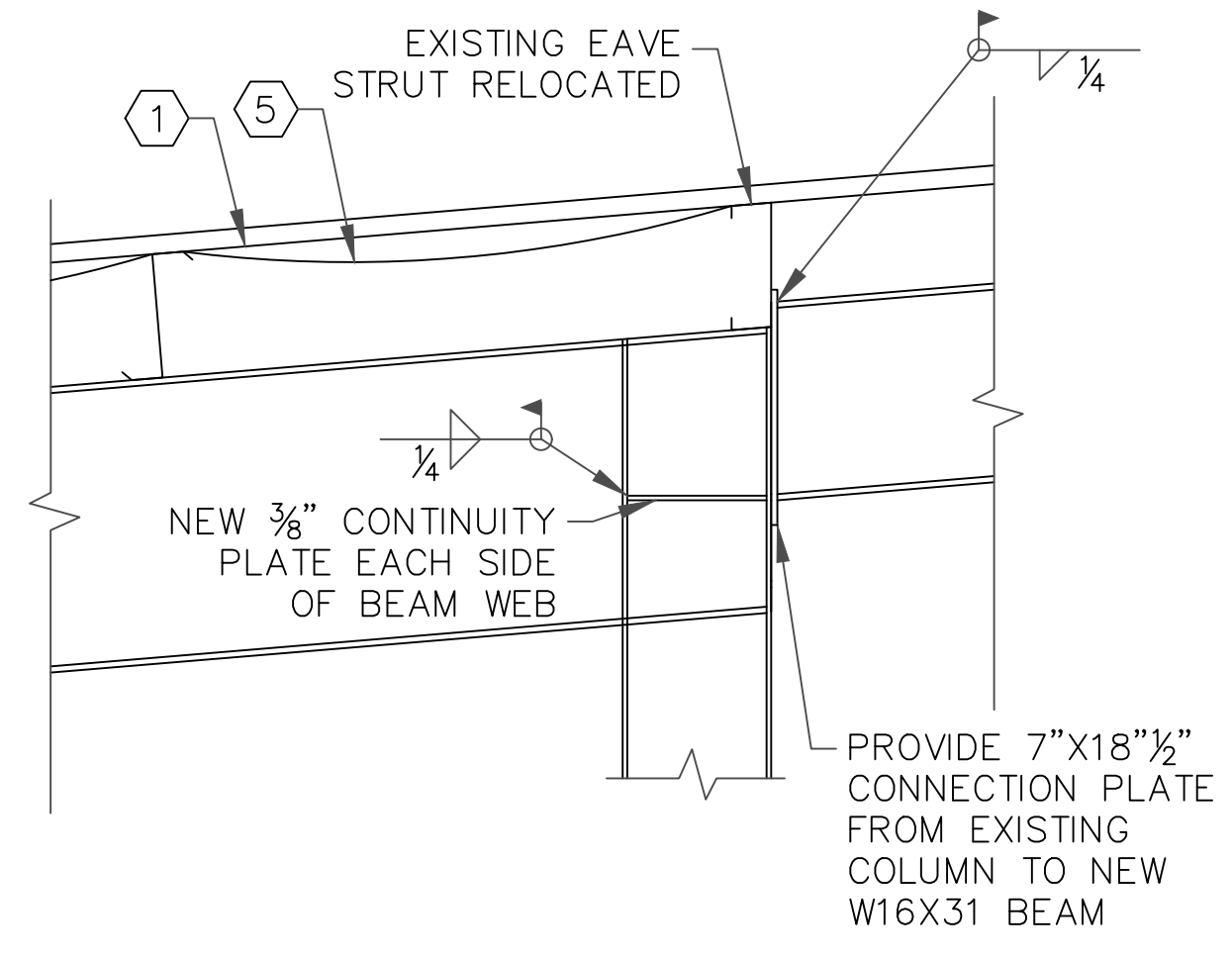
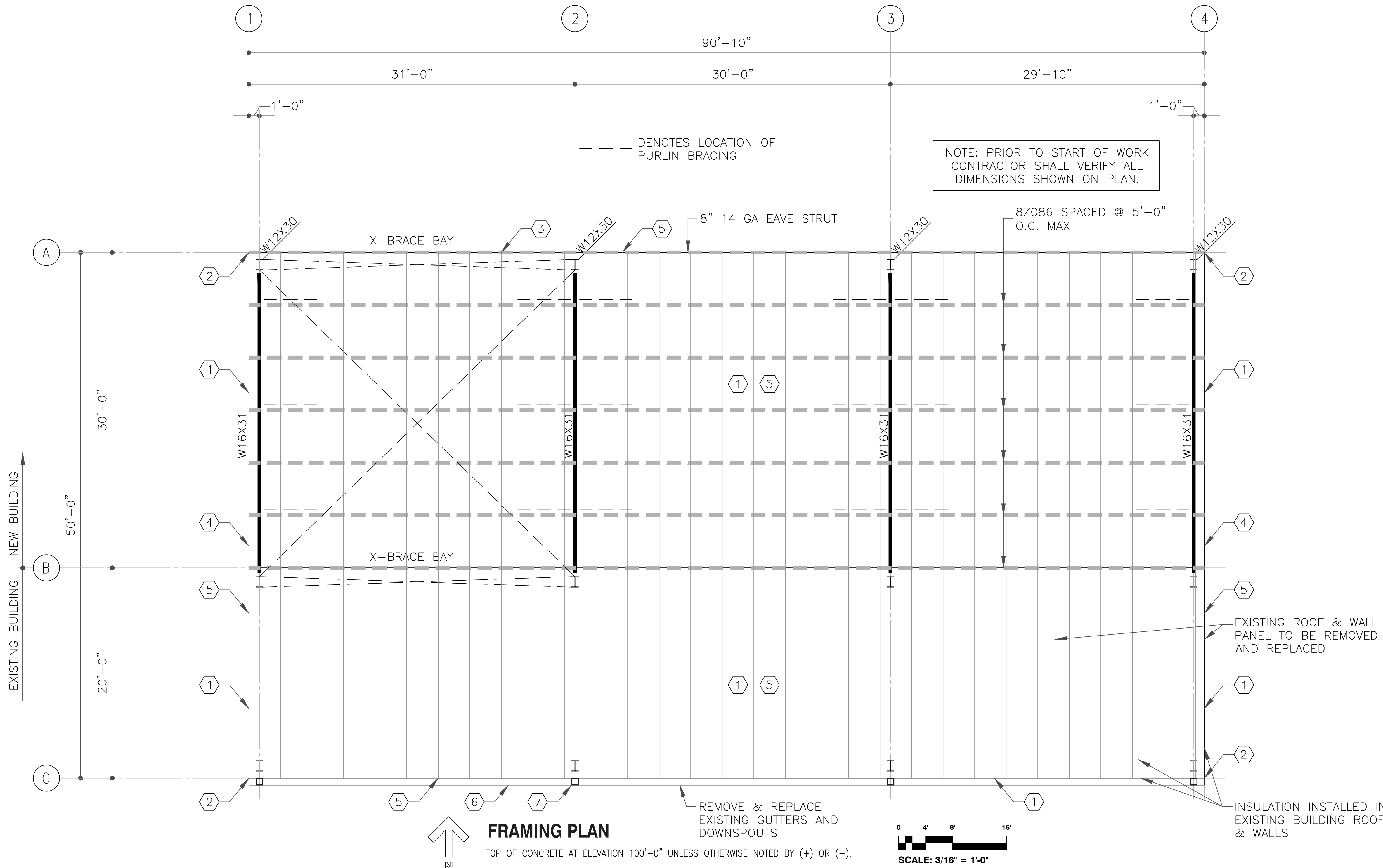

1 CONNECTION TO EXISTING STRUCTURE

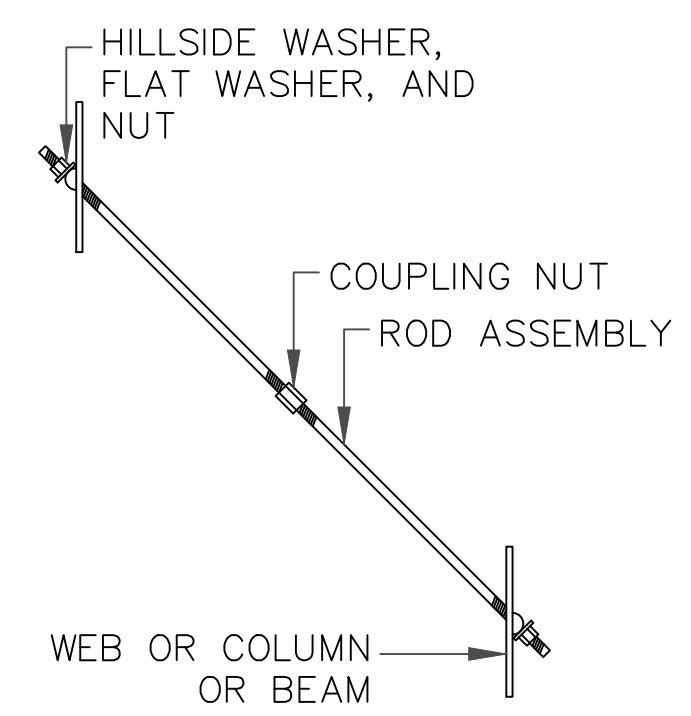

2 CONNECTION TO EXISTING STRUCTURE

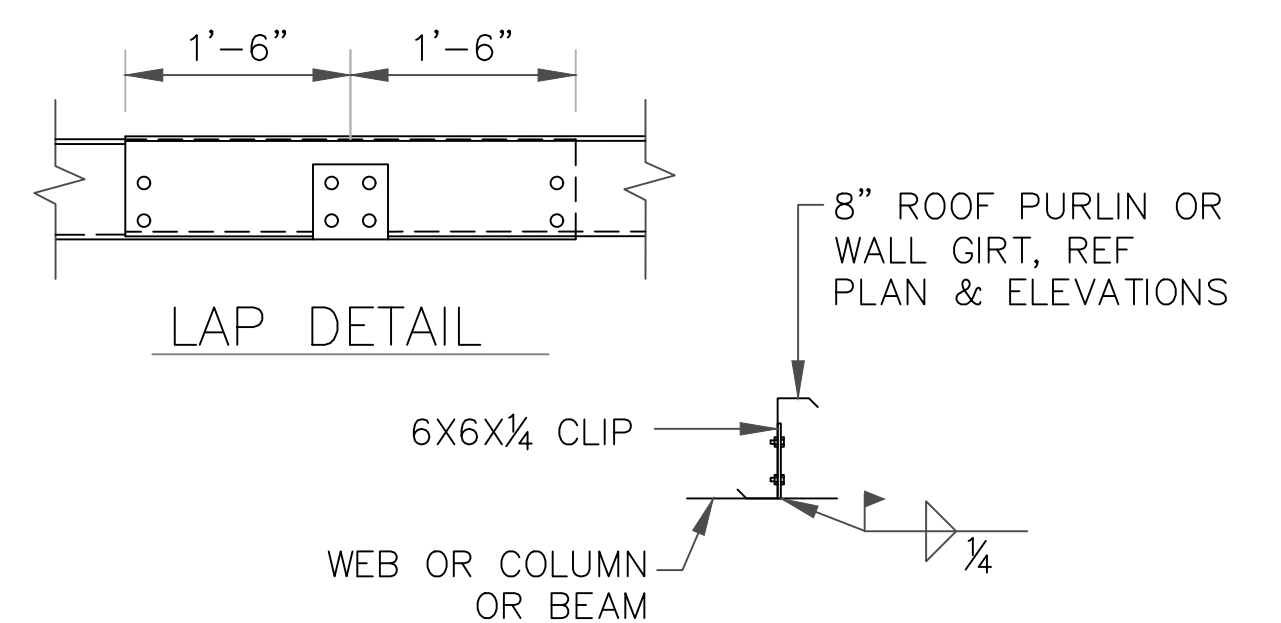

3 WALL GIRT AND ROOF PURLIN CONNECTION DETAIL

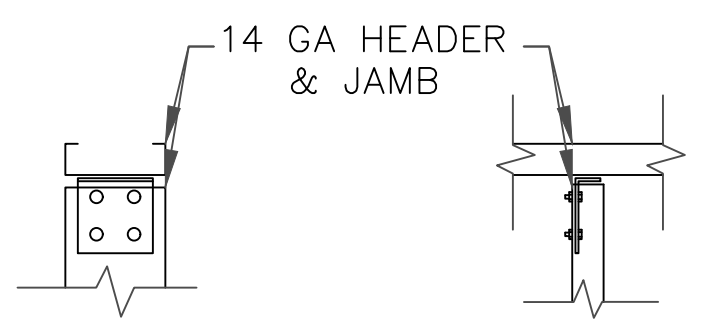

6 TYPICAL HEADER & JAMB DETAIL

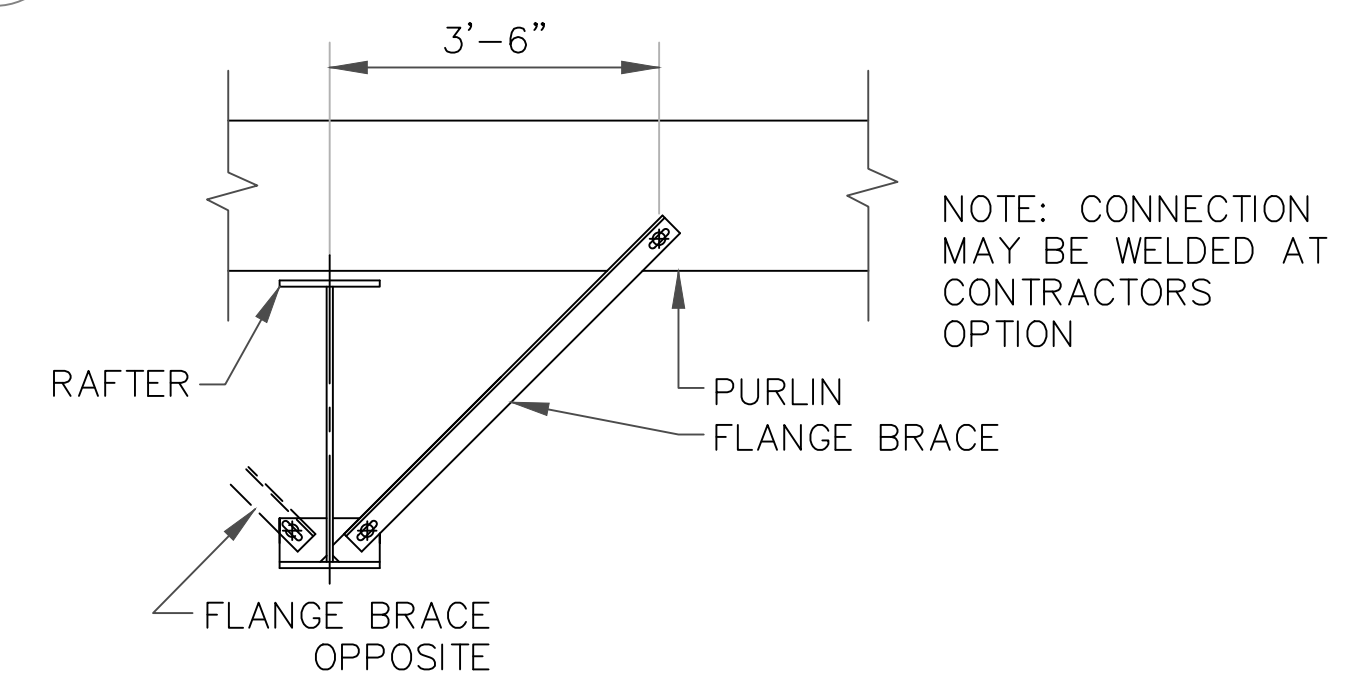

5 TYPICAL FLANGE BRACE @ PURLIN

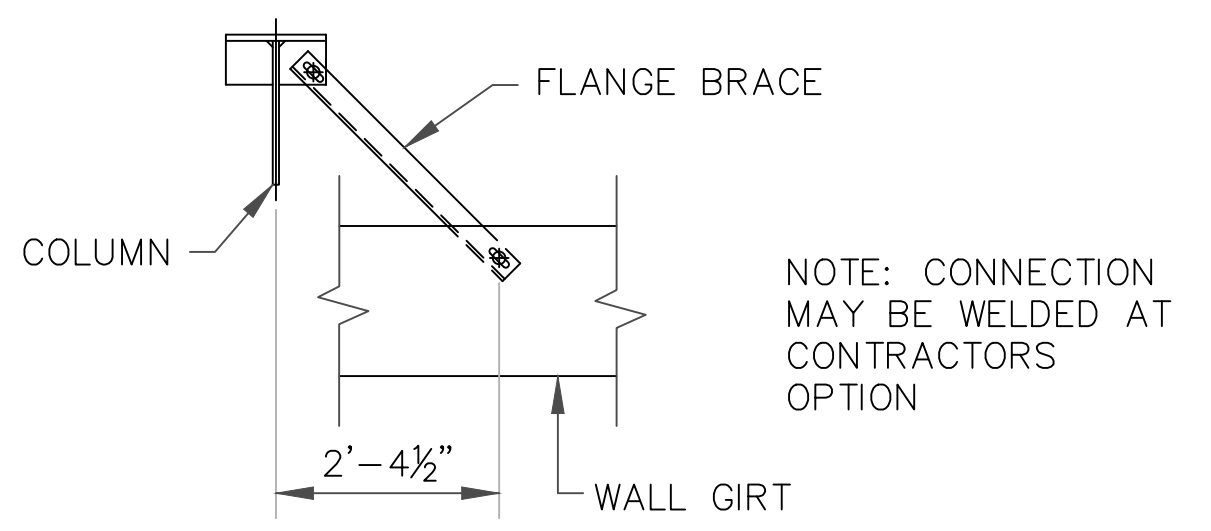

4 TYP FLANGE BRACE @ GIRT

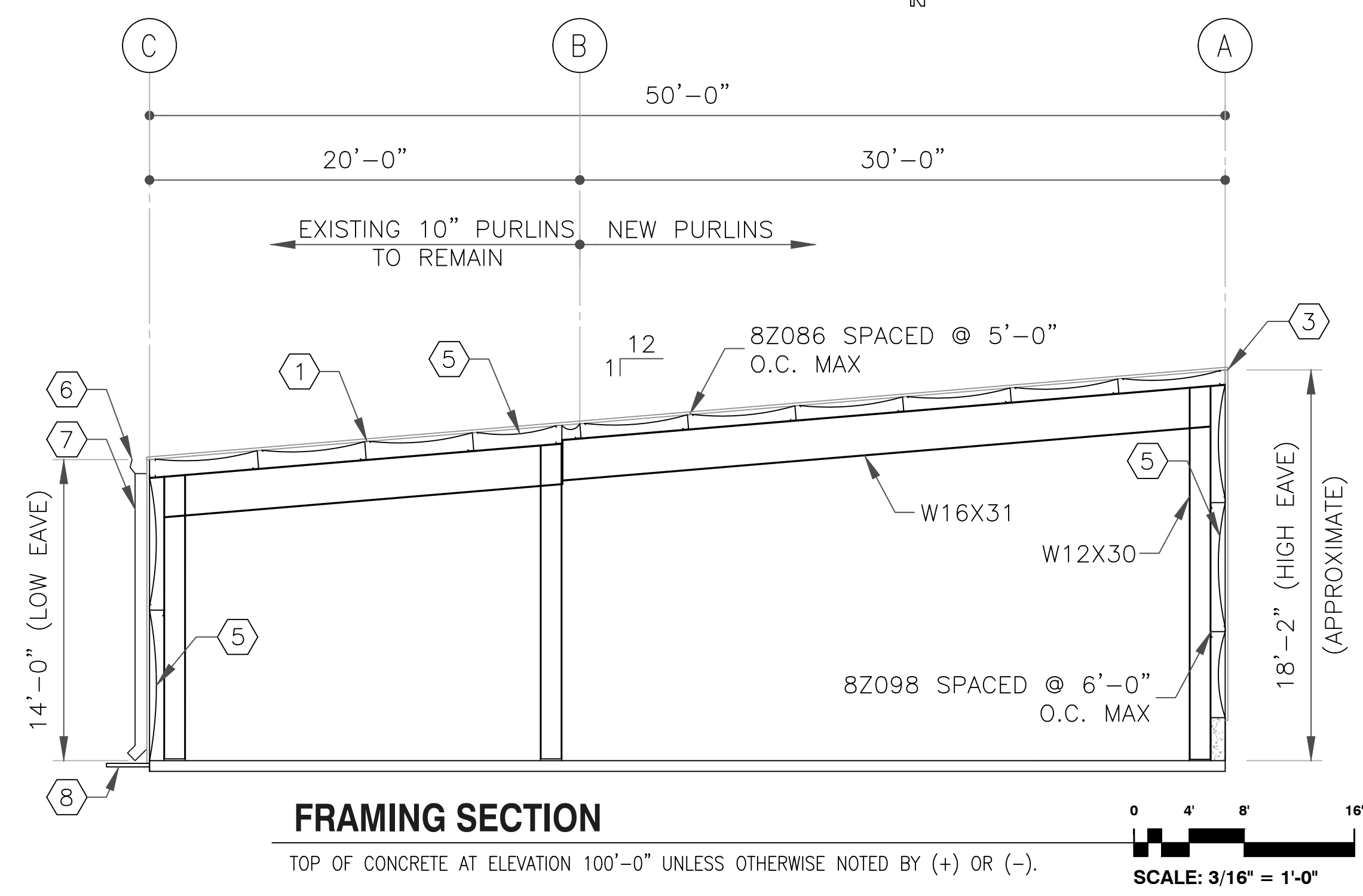



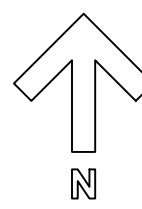
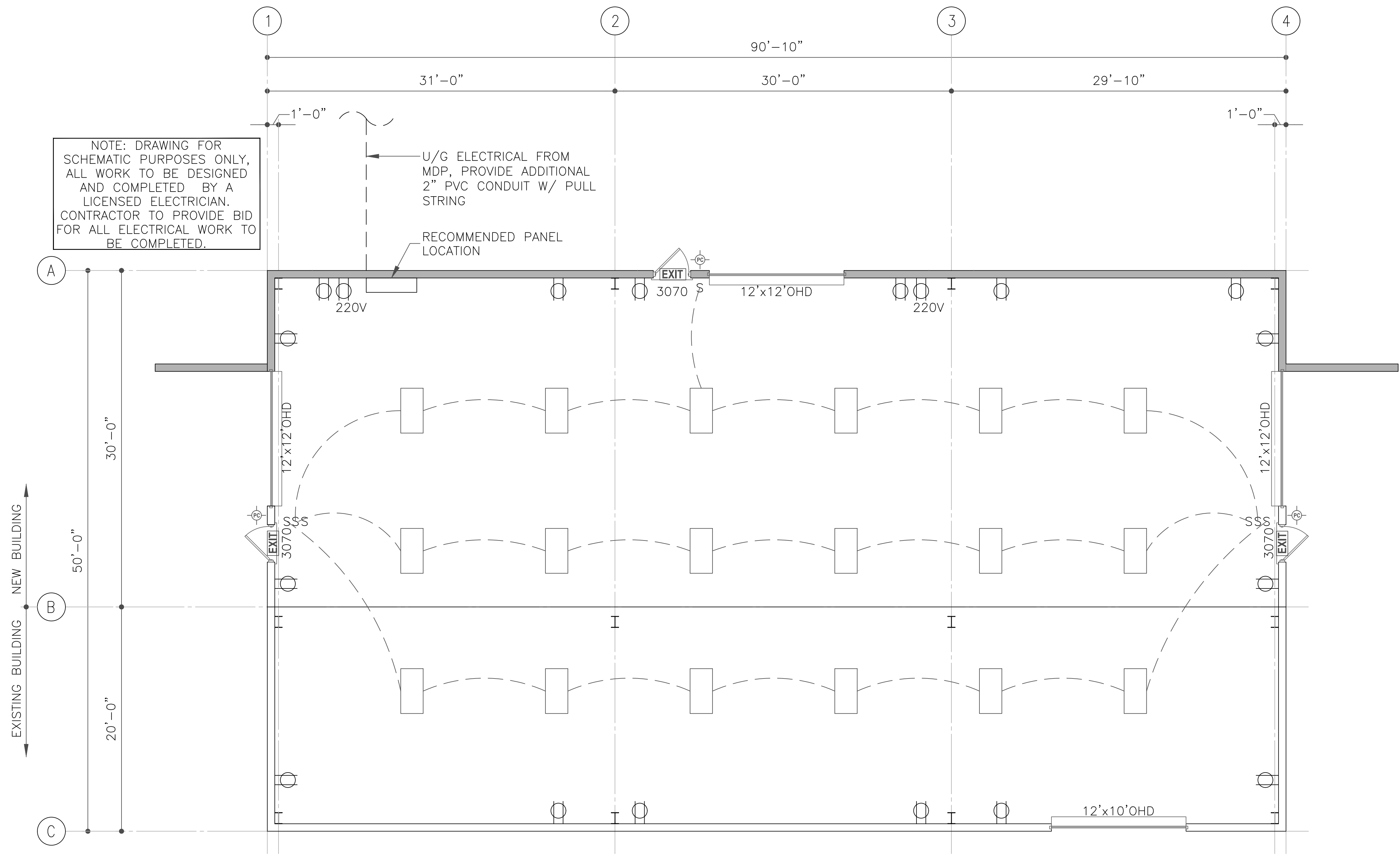



- KEYED NOTES:**
- 1 PRE-FINISHED METAL ROOF OR WALL PANELS (26GA MIN. GALVALUME, NON PAINTED). 3'-0" COVERAGE WIDTH. 3'-0" COVERAGE WIDTH.
  - 2 PRE-FINISHED CORNER TRIM.
  - 3 PRE-FINISHED FACIA TRIM..
  - 4 PRE-FINISHED RAKE TRIM.
  - 5 3" VINYL REINFORCED BATT INSULATION.
  - 6 NEW GALVALUME GUTTER
  - 7 NEW GALVALUME DOWNSPOUT
  - 8 NEW PRECAST SPLASH BLOCK AT EACH DOWNSPOUT

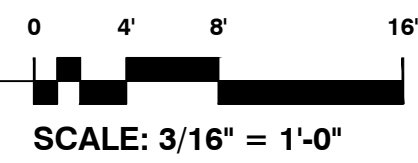

**LIGHTING & SWITCH PLAN**

TOP OF CONCRETE AT ELEVATION 100'-0" UNLESS OTHERWISE NOTED BY (+) OR (-).



-  NEW LED LIGHTING  
PROVIDE 20 FC (MIN)
-  DUPLEX RECEPTACLE  
OUTLET (20 AMP)
-  220 VOLTAGE  
220V
-  LIGHT SWITCH
-  PHOTO CELL SECURITY LIGHT
-  EXIT EXIT LIGHTING